

USER'S GUIDE



Vaisala HUMICAP[®] Humidity and Temperature Transmitters HMD70U/Y

PUBLISHED BY

Vaisala Oyj
P.O. Box 26
FIN-00421 Helsinki
Finland

Phone (int.): +358 9 8949 1
Fax: +358 9 8949 2227

Visit our Internet pages at <http://www.vaisala.com/>

© Vaisala 2006

No part of this manual may be reproduced in any form or by any means, electronic or mechanical (including photocopying), nor may its contents be communicated to a third party without prior written permission of the copyright holder.

The contents are subject to change without prior notice.

Please observe that this manual does not create any legally binding obligations for Vaisala towards the customer or end user. All legally binding commitments and agreements are included exclusively in the applicable supply contract or Conditions of Sale.

Contents

1. PRODUCT DESCRIPTION	1
2. TO BE NOTED WHEN MEASURING HUMIDITY	2
3. INSTALLATION.....	3
3.1 Selecting the place of installation	3
3.2 Mounting.....	3
3.3 Grounding.....	4
3.4 Electrical connections and installation of the current module	5
3.4.1 Connection to an AC supply	6
3.5 Electronics.....	7
4. CALIBRATION	8
4.1 One-point humidity calibration	8
4.2 Two-point humidity calibration.....	8
4.2.1 Two-point humidity calibration procedure.....	8
4.3 Calibration table	9
5. MAINTENANCE.....	9
5.1 Replacing the HUMICAP[®] 180 sensor and the filter	9
6. TECHNICAL DATA.....	10
6.1 Relative humidity.....	10
6.2 Temperature (Y model only)	10
6.3 General.....	11
6.4 Electromagnetic compatibility	12
6.4.1 Emissions.....	12
6.4.2 Immunity	12
GUARANTEE	12

This page intentionally left blank.

1. PRODUCT DESCRIPTION

The HMD70 transmitters are duct mounted three-wire transmitters for the measurement of humidity (HMD70U) and for the measurement of humidity and temperature (HMD70Y).

The HMD70U/Y transmitters are easy to install and maintain: the electronics can be disconnected without dismantling the installation. One point calibration is easily performed with the HMI41 indicator and the calibration cable 19116ZZ.

Both transmitter types incorporate the HUMICAP[®]180 humidity sensor which uses an operating principle based on changes in the capacitance of a thin polymer film as it absorbs water molecules. The HMD70Y transmitters measure temperature with the reliable Pt 1000 sensor.

2. TO BE NOTED WHEN MEASURING HUMIDITY

In the measurement of humidity and especially in calibration, it is essential that the temperature equilibrium is reached. Even a slight difference in the temperature between the measured object and the sensor causes an error. For example, at +20 °C (+ 68 °F) and 50 %RH, a temperature difference of ± 1 °C between the measured object and the sensor causes an error of ± 3 %RH. If relative humidity is 90 %RH, the error is about ± 5.4 %RH.

The error is at its greatest when the temperature of the sensor differs from that of the surroundings and the humidity is high. A few degrees' difference in temperature may cause water to condense on sensor surface. Efficient ventilation accelerates evaporation whereas in an unventilated space, it may take hours. The HUMICAP[®]180 sensor returns to its normal functioning as soon as water has evaporated. Any contaminated water condensing on the sensor may shorten its life span and change the calibration.

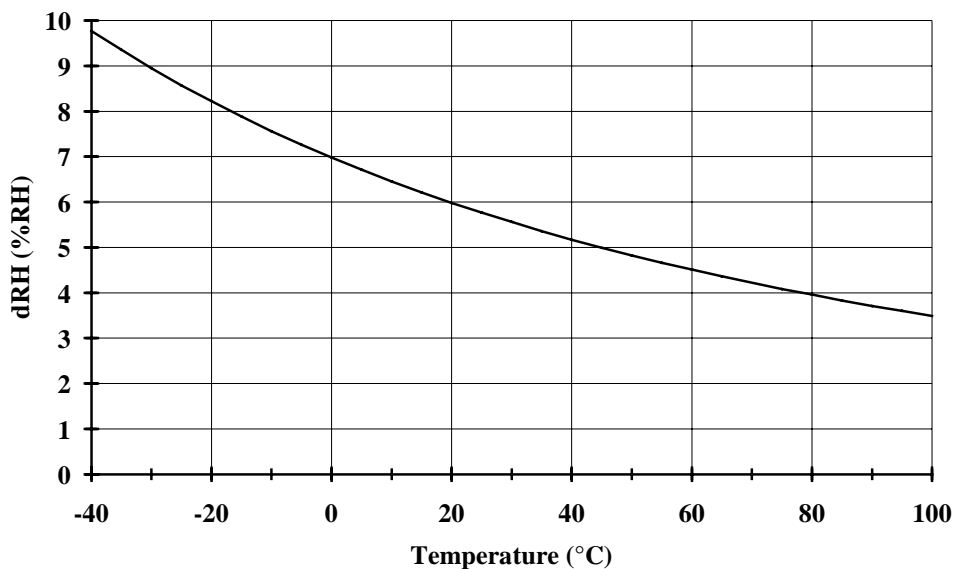

Figure 2.1 Measurement error at 100 %RH when the temperature difference between the ambient and the sensor is 1 °C

3. INSTALLATION

3.1 Selecting the place of installation

Select a place that gives a true picture of the environment or process and is as clean as possible. Air should circulate freely around the sensor. A rapid air flow is recommended as it ensures the same temperature for the ambient air and the sensor head.

Install the transmitter in a place where no cold or hot spot can develop. If the sensor head is installed in a duct or channel where the temperature is different from the ambient temperature, insulate the point of entry. An uninsulated installation might lead to condensation on the sensor head and even if no condensation occurs, the resultant air flow may change the temperature near the sensor head and distort the readings.

3.2 Mounting

Mount the transmitter with two screws. Place the drilling template on the duct surface and drill the holes as indicated. Remember to drill an additional hole for calibration purposes.

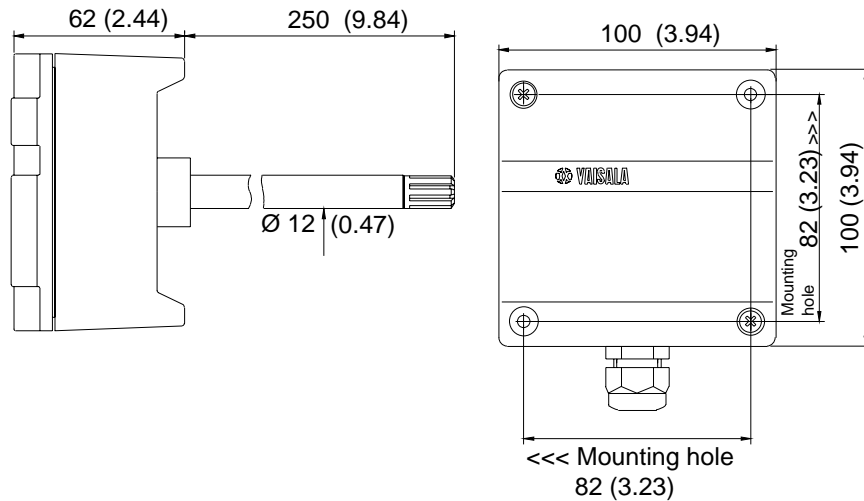

Figure 3.2 Dimensions of the HMD70U/Y (in mm)

3.3 Grounding

Open the lid and mount the cable bushing set 18941HM. Do the grounding according to Figure 3.3. When connecting the signal cable to the transmitter housing, fold the cable braid between the brass disk in order to achieve the best possible EMC performance. **Do not leave the bare shield of the connected wires so that it can shortcircuit the electronics!**

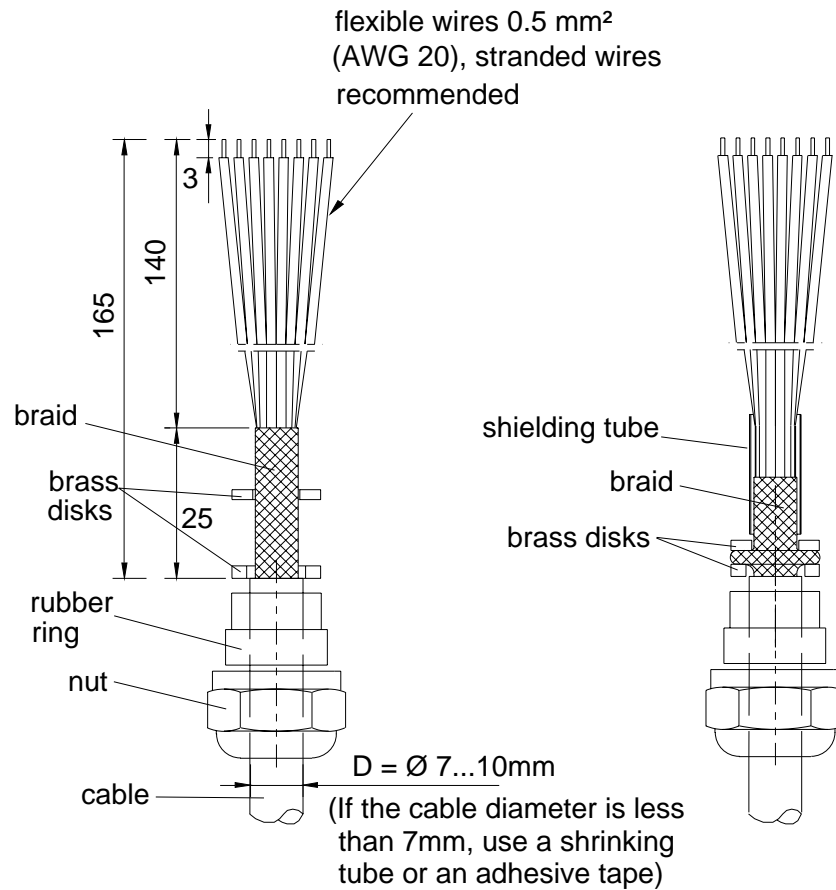

Figure 3.3 Signal cable grounding with bushing 18941HM

3.4 Electrical connections and installation of the current module

Figure 3.4 shows the electrical connections and the installation of the current module.

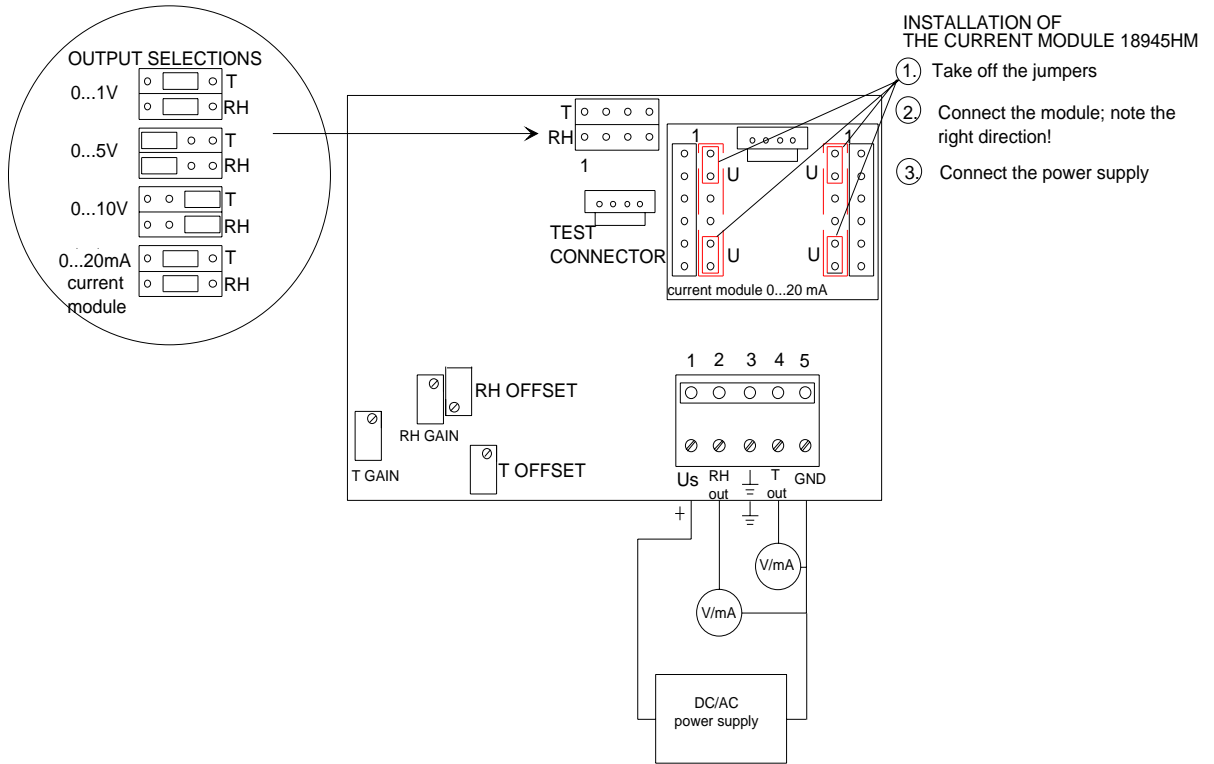

Figure 3.4 Electrical connections and installation of the current module

3.4.1 Connection to an AC supply

The HMD70U/Y transmitters can also be connected to an AC supply without an external rectifier. However, when more than one transmitter is connected to one AC transformer, a common loop is formed and there is an increased risk of a short-circuit. To avoid this, use a separate floating supply for each transmitter (see Figure 3.4.1.1). However, if several transmitters have to share one transformer, the phase (~) must always be connected to Us connector in each transmitter (see Figure 3.4.1.1).

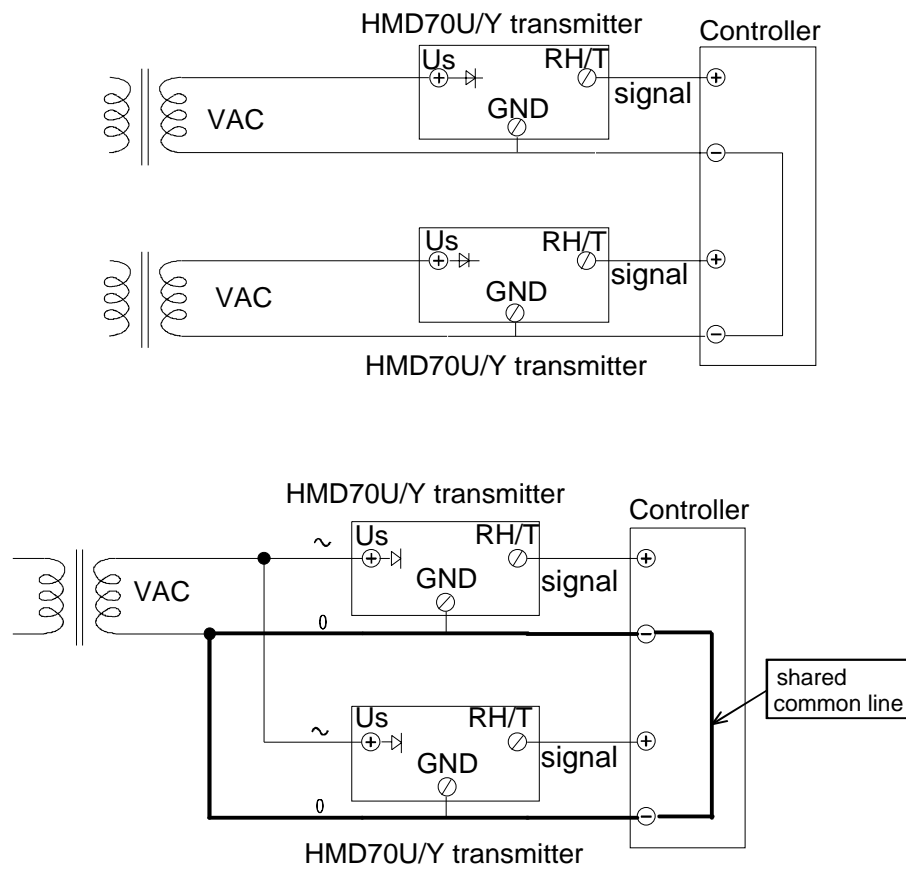
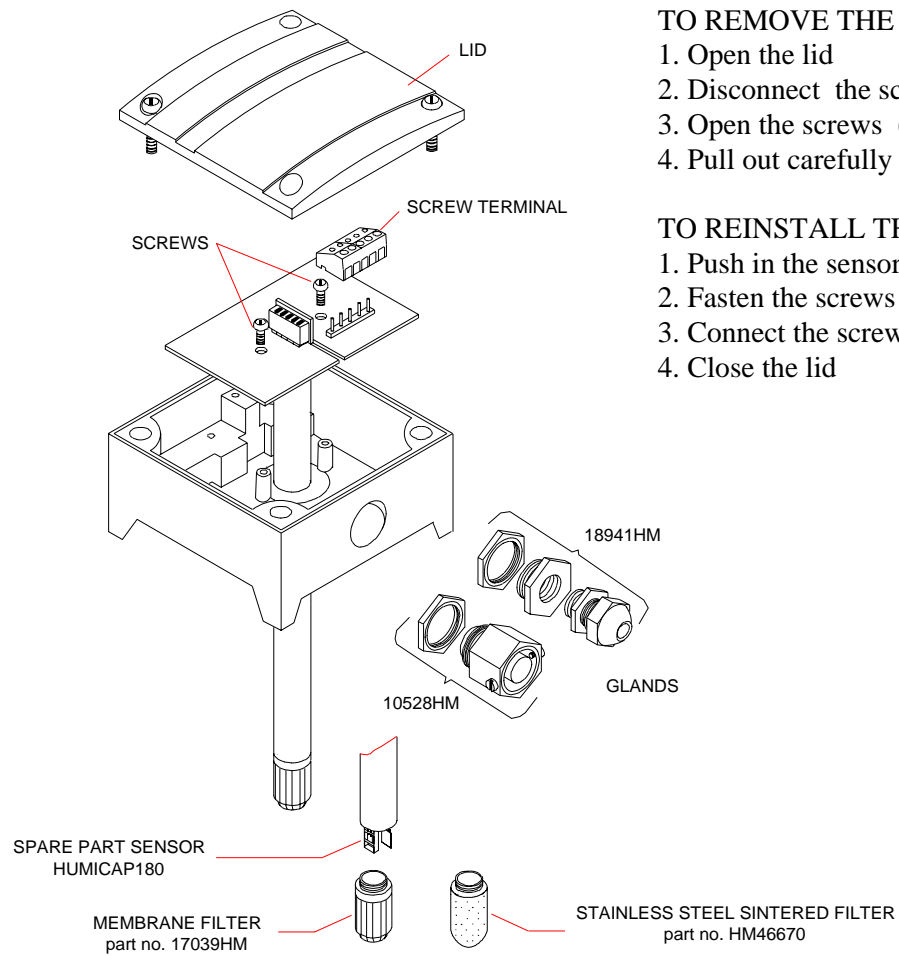

Figure 3.4.1.1 Connection to an AC supply

3.5 Electronics



TO REMOVE THE SENSOR HEAD:

1. Open the lid
2. Disconnect the screw terminal
3. Open the screws (2 pcs)
4. Pull out carefully

TO REINSTALL THE SENSOR HEAD:

1. Push in the sensor head
2. Fasten the screws
3. Connect the screw terminal
4. Close the lid

Figure 3.5 Electronics (can be disconnected), accessories, spare parts

4. CALIBRATION

4.1 One-point humidity calibration

The accuracy is recommended to be checked at least once a year; the interval depends on the operating conditions and the required accuracy of the measurement. The transmitter calibration can be conveniently checked with the HMI41 indicator equipped with an appropriate probe and optional calibration cable. If adjustment is needed, use the one-point calibration potentiometer. If you prefer to calibrate the HMD70U/Y transmitters against saturated salt solutions, use LiCl (11 %RH) and NaCl (75 %RH) solutions.

4.2 Two-point humidity calibration

The calibration can also be done with salt calibrators, or the instrument can be sent to Vaisala or a Vaisala representative.

4.2.1 Two-point humidity calibration procedure

- Leave the calibrator and the transmitter for at least 30 minutes in the same space so that their temperatures have time to equalize.
- Place the probe into the calibration hole of the LiCl bottle in the humidity calibrator.
- Wait for 10 minutes.
- Use the RH offset potentiometer (Figure 3.4.) to adjust the output signal to the value given in the calibration table (Chapter 4.3).
- Place the probe into the calibration hole of the NaCl bottle in the calibrator.
- Wait for 10 minutes.
- Check that the reading corresponds within the desired accuracy to the reading given in the calibration table. If not, adjust the reading with the RH gain potentiometer (Figure 3.4).
- Check again the reading at the first point and adjust if necessary.

4.3 Calibration table

Temperature	°C	15	20	25	30	35
	°F	59	68	77	86	95
LiCl	%RH	*)	11.3	11.3	11.3	11.3
4...20 mA	mA		5.81	5.81	5.81	5.81
0...20 mA	mA		2.26	2.26	2.26	2.26
0...1 V	V		0.113	0.113	0.113	0.113
0...5 V	V		0.565	0.565	0.565	0.565
0...10 V	V		1.13	1.13	1.13	1.13
NaCl	%RH	75.6	75.5	75.3	75.1	74.9
4...20 mA	mA	16.10	16.08	16.05	16.02	15.98
0...20 mA	mA	15.12	15.10	15.06	15.02	14.98
0...1 V	V	0.756	0.755	0.753	0.751	0.749
0...5 V	V	3.780	3.775	3.765	3.755	3.745
0...10 V	V	7.56	7.55	7.53	7.51	7.49

*) LiCl solution must not be used or stored in temperatures below +18 °C (+64 °F); otherwise the equilibrium humidity of the salt solution changes permanently

Table 1 Greenspan's calibration table with output values according to the chosen scale

5. MAINTENANCE

5.1 Replacing the HUMICAP[®] 180 sensor and the filter

Remove the damaged sensor and insert a new one. Handle the sensor by the plastic socket. **DO NOT TOUCH THE SENSOR PLATE.** Recalibrate the transmitter.

Replace a dirty filter (membrane or sintered) to ensure a maximum lifetime and a fast response for the sensor. Do not try to clean the filter.

6. TECHNICAL DATA

6.1 Relative humidity

Measurement range 0...100 %RH

Accuracy at 20 °C:

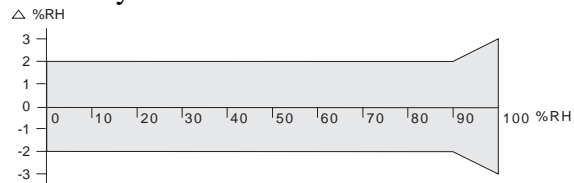

Temperature dependence:

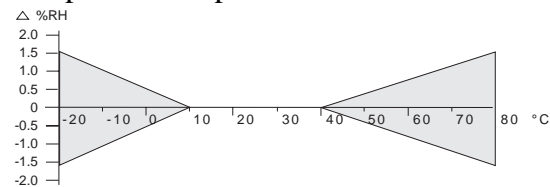

Response time (90%) at +20 °C in still air 15 s with membrane filter

Humidity sensor HUMICAP®180

6.2 Temperature (Y model only)

Measurement range -20...+80 °C

Accuracy:

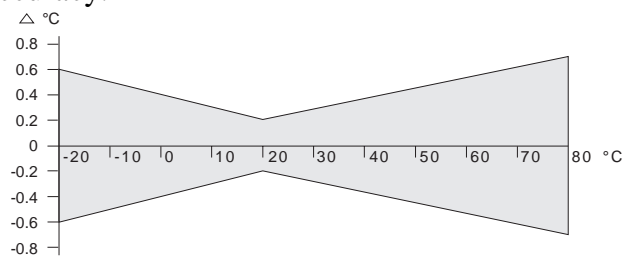

Linearity better than 0.1 °C

Temperature sensor Pt 1000 IEC 751class B

6.3 General

Supply voltage range depends on the selected output signal.
When AC supply is used, an isolated source is recommended.
The current outputs require an optional output module,
part no.18945HM.

	DC	AC
0...1 V	10...35 V	9...24 V
0...5 V	14...35 V	12...24 V
0...10 V	19...35 V	16...24 V
0...20 mA ($R_L = 0 \Omega$)	10...35 V	11...24 V
0...20 mA ($R_L = 500 \Omega$)	20...35 V	17...24 V

Factory setting 0...1V. Other outputs selectable by jumper connections.
An output change causes an error which is less than 0.5 %RH
without recalibration.

Operating temperature range:

electronics	-5...+55 °C
sensor head	-40...+80 °C

Storage temperature range -40...+80 °C

Housing:

sensor head	stainless steel
electronics housing	cast aluminium

Cable glands

bushing	for 7...10 mm (PG9) cable (housing IP65/ NEMA 4), part no 18941HM
or armoured cable glands	part no 10528HM

Sensor protection:

standard	membrane filter (part no. 17039HM)
option	stainless steel sintered filter (part no. HM46670)

Connections

screw terminals 0.5...1.5 mm²

6.4 Electromagnetic compatibility

The emission and immunity tests have been performed according to standards EN50081-1 and EN50082-1.

6.4.1 Emissions

Test	Setup according to	Performance
Radiated interference	EN55022	class B

6.4.2 Immunity

Test	Setup according to	Performance
Electrostatic discharge	IEC 801-2:1991	criteria B
Electrical fast transients	IEC 801-4:1988	criteria B
RF-radiated fields	IEC 801-3:1984	criteria A
*GSM-field immunity	ENV50204:1995	criteria A

(* additional test)



GUARANTEE

Vaisala issues a guarantee for the material and workmanship of this product under normal operating conditions for one year from the date of delivery. Exceptional operating conditions, damage due to careless handling or misapplication will void the guarantee.



www.vaisala.com