

USER'S GUIDE

Vaisala HUMICAP[®] Humidity and Temperature Transmitter Series HMT360



PUBLISHED BY

Vaisala Oyj Phone (int.): +358 9 8949 1
P.O. Box 26 Fax: +358 9 8949 2227
FIN-00421 Helsinki
Finland

Visit our Internet pages at <http://www.vaisala.com/>

© Vaisala 2007

No part of this manual may be reproduced in any form or by any means, electronic or mechanical (including photocopying), nor may its contents be communicated to a third party without prior written permission of the copyright holder.

The contents are subject to change without prior notice.

Please observe that this manual does not create any legally binding obligations for Vaisala towards the customer or end user. All legally binding commitments and agreements are included exclusively in the applicable supply contract or Conditions of Sale.



Table of Contents

CHAPTER 1	
GENERAL INFORMATION	9
About This Manual	9
Contents of This Manual	9
Version Information	11
Related Manuals	11
General Safety Considerations	11
Feedback	12
Product Related Safety Precautions	12
ESD Protection	12
Recycling	13
Regulatory Compliances	13
Trademarks	13
License Agreement	13
Warranty	14
CHAPTER 2	
PRODUCT OVERVIEW	15
Introduction to Vaisala HUMICAP® Humidity and Temperature Transmitter Series HMT360	15
Output Quantities	16
Probe Options	17
CHAPTER 3	
INSTALLATION	19
General Installation Instructions	19
Mounting the Probe Cable in Gas Group IIC Spaces	19
Selecting Location	20
General Instructions for Probes with Cable	20
Checking the Temperature Reading	22
Mounting the Transmitter Housing	22
Probe Mounting	25
HMP363 for Confined Spaces	25
HMP363/365/367 Duct Installation Kit	26
HMP364 for High-Pressure Applications	26
HMP365 for High Temperatures	29
HMP367 for High Humidities	29
HMP368 for Pressurized Pipelines or Moisture in Liquids	30
Tightening the Clasp Nut	31
Installing the HMP368 Probe Through a Ball Valve Assembly	32

Electrical Connections	35
Installation in Hazardous Locations	36
US and Canadian Requirements	36
European Requirements	36
CATEGORY 1 (Zone 0)	36
CATEGORY 2 or 3 (Zone 1 or 2)	36
Maximum Cable Resistance Calculation for the Barrier (Vaisala Order Code: 210664)	37
HMT360 Connected to a Galvanic Isolator	39
HMT360 Connected to a Zener Barrier	40
Examples of Connections	41
Grounding	42
 CHAPTER 4	
OPERATION	43
Local Interface	43
Power ON/OFF	44
HMT360 with Display	44
HMT360 without Display	44
DIP Switch Functions	45
Display/Keypad Commands	46
Setting the Pressure for Calculations	46
Selecting Output Quantities	47
Upper Half of Display	47
Lower Half of Display	48
Selecting Analog Outputs	48
Scaling Analog Outputs	49
Serial Interface	50
Serial Communication Settings	51
Setting the Analog Outputs	51
ASEL Selecting Analog Outputs	51
S Scaling Analog Outputs	52
Adjustment Commands	53
CRH Relative Humidity Adjustment	53
CT Temperature Adjustment	53
Output Commands	54
ITEST Testing Analog Outputs	54
SEND Outputting Measurement Values	55
R Activating Continuous Output	55
S Stopping Continuous Output	55
INTV Setting Output Interval	55
PRES Setting Ambient Pressure for Calculations	56
FILT Output Filtering	57
Resetting the Transmitter	57
RESET Transmitter Reset	57
 CHAPTER 5	
MEASURING AT OVERPRESSURE	59
Pressure Regulator Recommended	60

CHAPTER 6	
CALIBRATION AND ADJUSTMENT	61
Calibration Interval	61
Factory Calibration and Adjustment	61
User Calibration and Adjustment	62
Removing the Electronics Unit	62
Connections	63
Calculating Correspondence of Current Values and Output Quantities	64
Relative Humidity Adjustment	65
Automatic Two-Point Adjustment (Only with HMT360 with Display)	65
Manual Adjustment	67
Low End Adjustment	67
High End Adjustment (Two-Point Adjustment)	68
One-Point Temperature Adjustment	68
ACAL Analog Output Calibration	69
 CHAPTER 7	
MAINTENANCE	71
Periodical Checking and Cleaning	71
Transmitter Housing and Probe	71
 CHAPTER 8	
TROUBLESHOOTING	73
Diagnostics	73
Operation Errors	73
Analog Output Test	74
Technical Support	74
Return Instructions	74
Vaisala Service Centers	75
 CHAPTER 9	
TECHNICAL DATA	77
Performance	77
Relative Humidity	77
Temperature (+ Operating Pressure Ranges)	78
Water Activity in Jet Fuel Applications	79
Calculated Variables (Typical Ranges)	80
With HMP361 Probe	80
With HMP363, HMP364, HMP365, HMP367 and HMP368 Probes	80
Outputs	80
Classification with Current Outputs	81
General	82
Options and Accessories	83
Accuracy of Calculated Variables	84

Accuracy of Dewpoint Temperature °C	85
Accuracy of Mixing Ratio g/kg	86
Accuracy of Wet Bulb Temperature °C	86
Accuracy of Absolute Humidity g/m3	87
APPENDIX A	
DIMENSIONS	89
HMP361	89
HMP363	90
HMP364	90
HMP365	90
HMP367	91
HMP368	91
Mounting Plate	92
Rain Shield	92
Protection Cover	93
APPENDIX B	
WIRING FOR INTRINSICALLY SAFE OPERATION, FM	95
APPENDIX C	
WIRING FOR INTRINSICALLY SAFE OPERATION, CSA	97
APPENDIX D	
CERTIFICATES	99

List of Figures

Figure 1	Vaisala HUMICAP® Humidity and Temperature Transmitter Series HMT360	16
Figure 2	Probe Options for Vaisala HUMICAP® Humidity and Temperature Transmitter Series HMT360	18
Figure 3	Horizontal Mounting of Probe	20
Figure 4	Vertical Mounting of Probe	21
Figure 5	Measurement Error at 100 %RH	22
Figure 6	Transmitter Mounting	23
Figure 7	Parts of the Transmitter	24
Figure 8	Installation of HMP363 Probe in Duct with Flange and Supporting Bar	26
Figure 9	HMP364 Probe Mounting	27
Figure 10	Marking Nut and Fitting Screw	28
Figure 11	Cleaning the Tightening Cone	28
Figure 12	Mounting HMP365 Probe in Duct or Channel	29
Figure 13	HMP368 Probe	30
Figure 14	Sealing of Fitting Body into Process	31
Figure 15	Tightening the Clasp Nut	32
Figure 16	Installing the HMP368 Probe Through a Ball Valve Assembly	33
Figure 17	HMT360 Connected to Galvanic Isolator	39
Figure 18	HMT360 Connected to a Zener Barrier	40
Figure 19	STAHL 9160/13-11-11 (Galvanic Isolator)	41
Figure 20	STAHL 9001/51-280-091-141 (Zener Barrier)	41
Figure 21	Grounding	42
Figure 22	Local Display/Keypad Interface	44
Figure 23	DIP Switch Functions	45
Figure 24	Detaching the Electronics Unit with Probe for Calibration and Adjustment	62
Figure 25	Connecting Power Supply and Multimeter for Calibration	63
Figure 26	Display Chart of the Automatic Adjustment Procedure	66
Figure 27	Accuracy over Temperature Range	79

List of Tables

Table 1	Manual Revisions	11
Table 2	Related Manuals	11
Table 3	Output Quantities for Vaisala HUMICAP® Humidity and Temperature Transmitter Series HMT360	16
Table 4	HMP368 Probe Dimensions	31
Table 5	Serial Communications Settings	51
Table 6	Pressure Conversion Chart	56
Table 7	Relative Humidity Specifications	77
Table 8	Temperature Specifications	78
Table 9	Water Activity in Jet Fuel Applications Specifications	79
Table 10	HMP361 Calculated Variables Specifications	80
Table 11	HMP363, HMP364, HMP365, HMP367 & HMP368 Probes Calculated Variables Specifications	80
Table 12	Output Specifications	80
Table 13	General Specifications	82
Table 14	Options and Accessories	83

CHAPTER 1

GENERAL INFORMATION

This chapter provides general notes for the manual and the product.

About This Manual

This manual provides information for installing, operating, and maintaining the Vaisala HUMICAP[®] Humidity and Temperature Transmitter Series HMT360.

Contents of This Manual

This manual consists of the following chapters:

- Chapter 1, General Information: This chapter provides general notes for the manual and the product.
- Chapter 2, Product Overview: This chapter introduces the features, advantages, and the product nomenclature.
- Chapter 3, Installation: This chapter provides you with information that is intended to help you install this product.
- Chapter 4, Operation: This chapter contains information that is needed to operate this product.
- Chapter 5, Measuring at Overpressure: This chapter provides you with important information concerning measurement in conditions with pressure higher than the normal atmospheric pressure.

- Chapter 6, Calibration and Adjustment: This chapter contains instructions for checking the calibration and adjusting this product.
- Chapter 7, Maintenance: This chapter provides information that is needed in basic maintenance of the product.
- Chapter 8, Troubleshooting: This chapter describes common problems, their probable causes and remedies, and contact information.
- Chapter 9, Technical Data: This chapter provides technical data of the product.
- Appendix A, Dimensions: This Appendix contains parts drawings of the transmitter housing, probes and some transmitter mounting accessories with metric and nonmetric dimensions specified.
- Appendix B, Wiring for Intrinsically Safe Operation, FM: This appendix contains the wiring diagram for intrinsically safe operation approved by Factory Mutual (FM).
- Appendix C, Wiring for Intrinsically Safe Operation, CSA: This appendix contains the wiring diagram for intrinsically safe operation approved by the Canadian Standards Association (CSA).
- Appendix D, Certificates: This Appendix contains copies of the EXi intrinsically safe certificates issued for the HMT360 series.

Version Information

Table 1 Manual Revisions

Manual Code	Description
U336en-1.1	March 1999 - First version
M010056en-A	January 2001
M010056en-B	March 2002
M010056en-C	November 2002
M010056EN-D	May 2004
M010056EN-E	July 2005
M010056EN-F	August 2006 - New measurement probes and new transmitter housing introduced.
M010056EN-G	September 2007 - HUMICAP® 180R added as a new sensor type. New copies of certificates added in Appendix Certificates on page 99 .

Related Manuals

Table 2 Related Manuals

Manual Code	Manual Name
M210185EN-B	Humidity Calibrator HMK15 User's Guide

General Safety Considerations

Throughout the manual, important safety considerations are highlighted as follows:

WARNING

Warning alerts you to a serious hazard. If you do not read and follow instructions very carefully at this point, there is a risk of injury or even death.

CAUTION

Caution warns you of a potential hazard. If you do not read and follow instructions carefully at this point, the product could be damaged or important data could be lost.

NOTE	Note highlights important information on using the product.
-------------	---

Feedback

Vaisala Customer Documentation Team welcomes your comments and suggestions on the quality and usefulness of this publication. If you find errors or have other suggestions for improvement, please indicate the chapter, section, and page number. You can send comments to us by e-mail: manuals@vaisala.com.

Product Related Safety Precautions

The Series HMT360 Transmitter delivered to you has been tested for safety and approved as shipped from the factory. Note the following precautions:

WARNING	Ground the product, and verify outdoor installation grounding periodically to minimize shock hazard.
----------------	--

CAUTION	Do not modify the unit. Improper modification can damage the product or lead to malfunction.
----------------	--

ESD Protection

Electrostatic Discharge (ESD) can cause immediate or latent damage to electronic circuits. Vaisala products are adequately protected against ESD for their intended use. However, it is possible to damage the product by delivering electrostatic discharges when touching, removing, or inserting any objects inside the equipment housing.

To make sure you are not delivering high static voltages yourself:

- Handle ESD sensitive components on a properly grounded and protected ESD workbench. When this is not possible, ground yourself with a wrist strap and a resistive connection cord to the equipment chassis before touching the boards. When neither of the above is possible, at least touch a conductive part of the equipment chassis with your other hand before touching the boards.

- Always hold the boards by the edges and avoid touching the component contacts.

Recycling



Recycle all applicable material.



Dispose of batteries and the unit according to statutory regulations. Do not dispose of with regular household refuse.

Regulatory Compliances

The certifications that have been granted to the HMT360 Series, and the accompanying safety factors, are listed in section [Classification with Current Outputs on page 81](#).

Copies of the certificates and wiring diagrams are provided in the following appendices:

- [Appendix B, Wiring for Intrinsically Safe Operation, FM, on page 95](#)
- [Appendix C, Wiring for Intrinsically Safe Operation, CSA, on page 97](#)
- [Appendix D, Certificates, on page 99](#)

Trademarks

HUMICAP[®] is a registered trademark of Vaisala.

License Agreement

All rights to any software are held by Vaisala or third parties. The customer is allowed to use the software only to the extent that is provided by the applicable supply contract or Software License Agreement.

Warranty

Vaisala hereby represents and warrants all Products manufactured by Vaisala and sold hereunder to be free from defects in workmanship or material during a period of twelve (12) months from the date of delivery save for products for which a special warranty is given. If any Product proves however to be defective in workmanship or material within the period herein provided Vaisala undertakes to the exclusion of any other remedy to repair or at its own option replace the defective Product or part thereof free of charge and otherwise on the same conditions as for the original Product or part without extension to original warranty time. Defective parts replaced in accordance with this clause shall be placed at the disposal of Vaisala.

Vaisala also warrants the quality of all repair and service works performed by its employees to products sold by it. In case the repair or service works should appear inadequate or faulty and should this cause malfunction or nonfunction of the product to which the service was performed Vaisala shall at its free option either repair or have repaired or replace the product in question. The working hours used by employees of Vaisala for such repair or replacement shall be free of charge to the client. This service warranty shall be valid for a period of six (6) months from the date the service measures were completed.

This warranty is however subject to following conditions:

- a) A substantiated written claim as to any alleged defects shall have been received by Vaisala within thirty (30) days after the defect or fault became known or occurred, and
- b) The allegedly defective Product or part shall, should Vaisala so require, be sent to the works of Vaisala or to such other place as Vaisala may indicate in writing, freight and insurance prepaid and properly packed and labelled, unless Vaisala agrees to inspect and repair the Product or replace it on site.

This warranty does not however apply when the defect has been caused through

- a) normal wear and tear or accident;
- b) misuse or other unsuitable or unauthorized use of the Product or negligence or error in storing, maintaining or in handling the Product or any equipment thereof;
- c) wrong installation or assembly or failure to service the Product or otherwise follow Vaisala's service instructions including any repairs or installation or assembly or service made by unauthorized personnel not approved by Vaisala or replacements with parts not manufactured or supplied by Vaisala;
- d) modifications or changes of the Product as well as any adding to it without Vaisala's prior authorization;
- e) other factors depending on the Customer or a third party.

Notwithstanding the aforesaid Vaisala's liability under this clause shall not apply to any defects arising out of materials, designs or instructions provided by the Customer.

This warranty is expressly in lieu of and excludes all other conditions, warranties and liabilities, express or implied, whether under law, statute or otherwise, including without limitation any implied warranties of merchantability or fitness for a particular purpose and all other obligations and liabilities of Vaisala or its representatives with respect to any defect or deficiency applicable to or resulting directly or indirectly from the Products supplied hereunder, which obligations and liabilities are hereby expressly cancelled and waived. Vaisala's liability shall under no circumstances exceed the invoice price of any Product for which a warranty claim is made, nor shall Vaisala in any circumstances be liable for lost profits or other consequential loss whether direct or indirect or for special damages.

CHAPTER 2

PRODUCT OVERVIEW

This chapter introduces the features, advantages, and the product nomenclature.

Introduction to Vaisala HUMICAP[®] Humidity and Temperature Transmitter Series HMT360

Vaisala HUMICAP[®] Humidity and Temperature Transmitter Series HMT360 contains reliable, microprocessor-based two-wire instruments for measuring relative humidity and temperature in hazardous areas.

WARNING

In hazardous environments, the transmitters must always be connected via galvanic isolators or Zener barriers.



Figure 1 Vaisala HUMICAP® Humidity and Temperature Transmitter Series HMT360

Output Quantities

Vaisala HUMICAP® Humidity and Temperature Transmitter Series HMT360 is available either with or without a local display and with one or two current output channels.

Available output quantities are listed in the table below:

Table 3 Output Quantities for Vaisala HUMICAP® Humidity and Temperature Transmitter Series HMT360

Character	Quantity	Abbreviation	Availability
0	relative humidity	RH	A, D
1	temperature	T	A, D, F, H
2	dewpoint temperature	Td	D
3	absolute humidity	a	D
4	mixing ratio	x	D
5	wet bulb temperature	Tw	D
6	mass concentration of water	ppmw	H
7	water activity	aw	H, F

**Table 3 Output Quantities for Vaisala HUMICAP®
Humidity and Temperature Transmitter Series
HMT360**

Character	Quantity	Abbreviation	Availability
8	relative humidity of saturation	RS	H
9	saturation temperature	Ts	H

The characters used to indicate availability in the table above:

A = Available for HMT360 standard version

D = Available for HMT360 with optional calculations

F = Available for HMT360 Moisture and Temperature in oil transmitter

H = Available for HMT360 Moisture and Temperature in Jet Fuel transmitter

Probe Options

The HMT360 series has various options for probes and cable lengths (2 m, 5 m and 10 m). The available probe types are presented in the figure below.

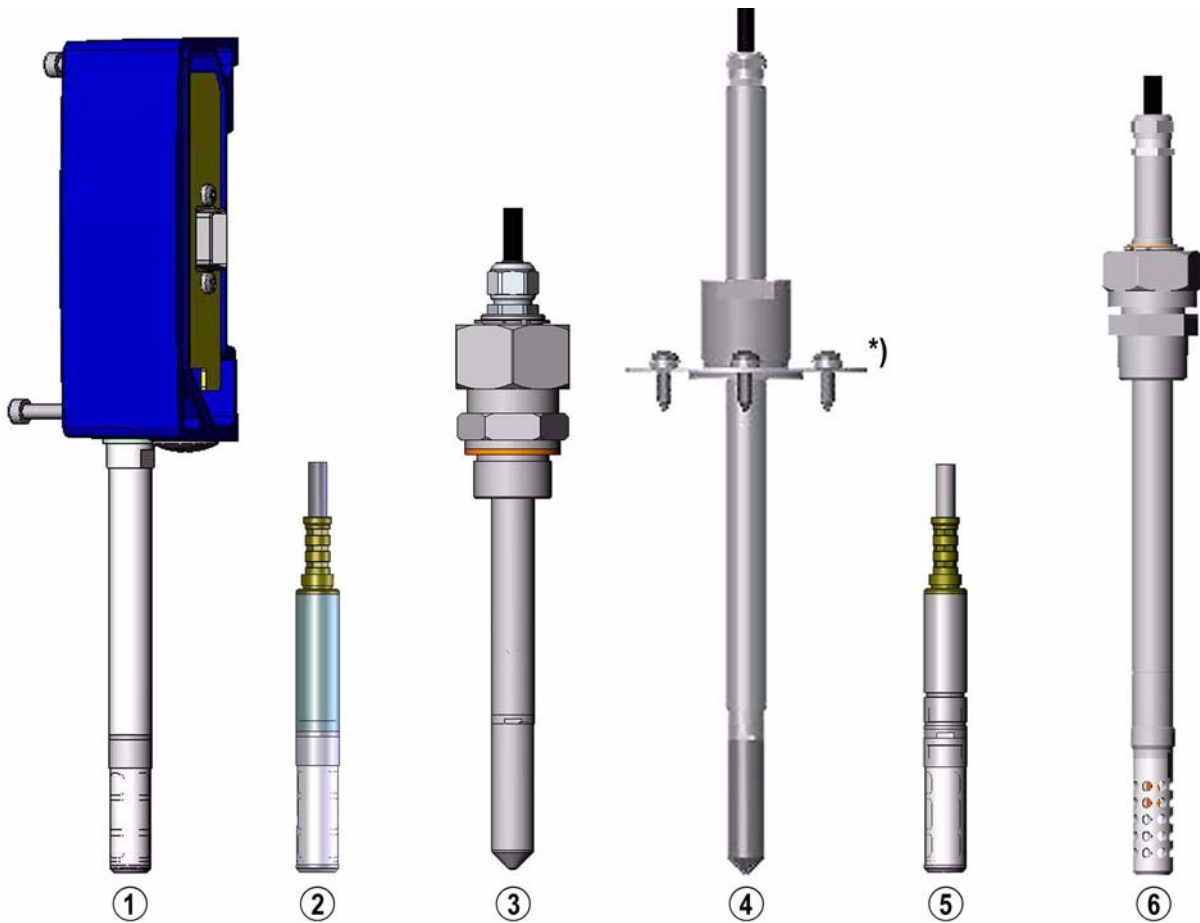

Figure 2 Probe Options for Vaisala HUMICAP® Humidity and Temperature Transmitter Series HMT360

The following numbers refer to [Figure 2 on page 18](#):

- 1 = HMP361 probe for wall mounting
- 2 = HMP363 probe for tight spaces
- 3 = HMP364 probe for pressurized spaces up to 100 bars
- 4 = HMP365 probe for high temperatures up to 180 °C *) Flange for HMP365 available as an option
- 5 = HMP367 probe for high humidities
- 6 = HMP368 probe for installations in pressurized pipelines up to 40 bars; features a pressure-tight sliding clasp nut

CHAPTER 3

INSTALLATION

This chapter provides you with information that is intended to help you install this product.

General Installation Instructions

Mounting the Probe Cable in Gas Group IIC Spaces

NOTE

The following applies only to installation within the EU!

The following instructions shall be followed to fulfil the specifications of the EN50284 for nonconductive layer of the probe cable:

- Never mount or handle the probe cable when hazardous gases are present.
- For achieving a conductive shield, cover the probe cable with conductive material like metal or conductive tape or mount the probe cable in a metal conduit.
- Assure that the conductive shield fulfils requirements of the standard EN50284 (resistance less than 1 G Ω) and make sure that it can not come loose in any operation situation.

WARNING During the installation work of the probes in gas group IIC areas (requiring category I devices), it has to be guaranteed that even in fault cases sparks generated by impacts or friction on the surface of the housing can never occur.

Selecting Location

Select a place with stable conditions for mounting the transmitter. Do not expose the transmitter to direct sunlight or rain. A rain shield is available and it is recommended for direct outdoor installations. When mounting the probe, select a place representing the process conditions.

General Instructions for Probes with Cable

Mount the probes with a cable horizontally; this way, any water condensing on the tube cannot flow onto the sensor.

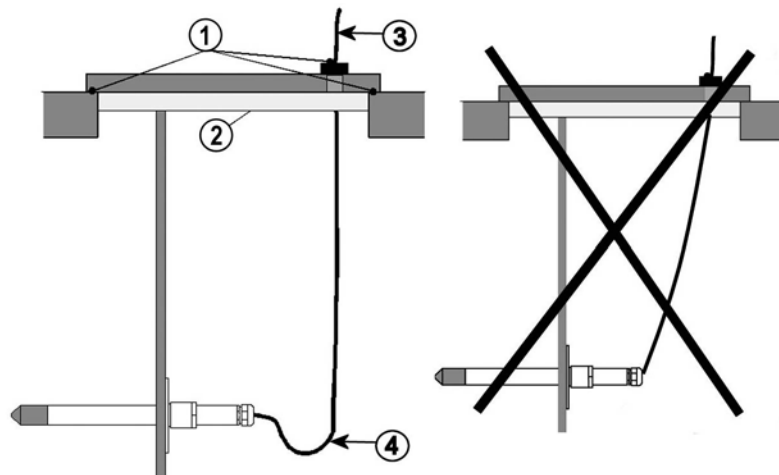

Figure 3 Horizontal Mounting of Probe

The following numbers refer to [Figure 3 on page 20](#):

- 1 = To be sealed
- 2 = To be insulated
- 3 = Insulate the cable
- 4 = Let the cable hang loosely. This prevents condensed water running to the sensor along the cable.

When there is no alternative but to install the probe in the process vertically, the point of entry must be carefully insulated. The cable must also be allowed to hang loosely as this prevents any condensed water from running onto the probe along the cable.

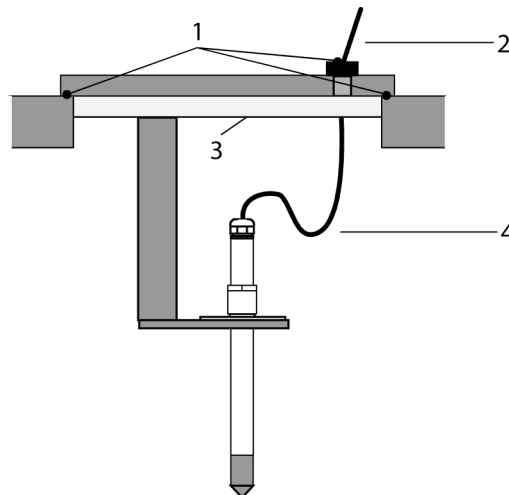

Figure 4 Vertical Mounting of Probe

The following numbers refer to [Figure 4 on page 21](#):

- 1 = To be sealed
- 2 = Insulate the cable
- 3 = To be insulated
- 4 = Let the cable hang loosely. This prevents condensed water running to the sensor along the cable

If the process temperature is much higher than that of the environment, the whole probe and preferably plenty of cable must be inside the process. This prevents measuring inaccuracy caused by heat conduction along the cable.

When mounted on the side of a duct or channel, the probe must be inserted from the side of the duct. If this is not possible and the probe must be inserted from the top, the point of entry must be carefully insulated.

For Vaisala probe installation kits and some installation examples see section [Probe Mounting on page 25](#).

Checking the Temperature Reading

The actual temperature of the process can be measured with a reference instrument to be compared with the transmitter reading. The heat transfer is less evident if you remove the protective filter of the sensor for a short-term test. However, never use the sensor long periods without the filter as this may cause a faster contamination of the sensor. The transmitter fulfils the specified EMC regulations with the protective filter on the probe.

In humidity measurement and especially in calibration and adjustment it is essential that temperature of the probe and measuring environment is the same. Even a small difference in temperature between the environment and the probe causes an error. As the curve below shows, if the temperature is +20 °C and the relative humidity 100 %RH, a difference of ± 1 °C between the environment and the probe causes an error of ± 6 %RH.

The graph below illustrates the measurement error at 100 %RH when the difference between the ambient and sensor temperature is 1 °C.

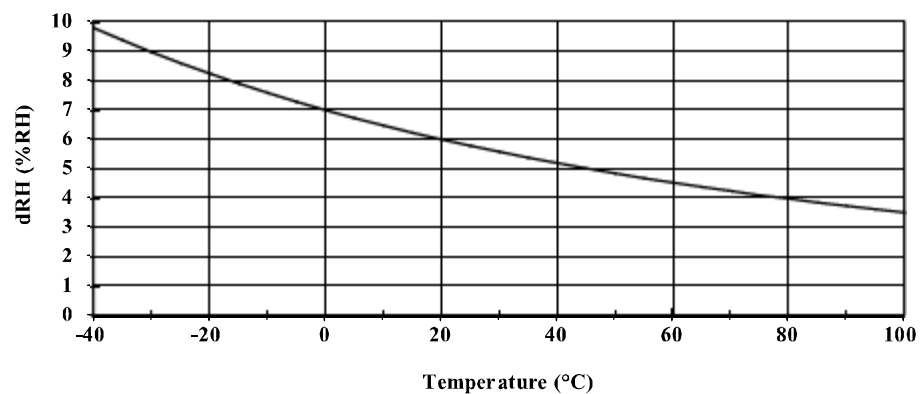

Figure 5 Measurement Error at 100 %RH

Mounting the Transmitter Housing

1. Attach the mounting plate to the wall with 4 screws.
2. Press down the transmitter so that it slides along the rails of the mounting plate.
3. Fasten the transmitter to the mounting plate with the Allen screw (3 mm Allen key provided).

The probe can be detached and replaced when needed by simply unfastening the two Allen screws.

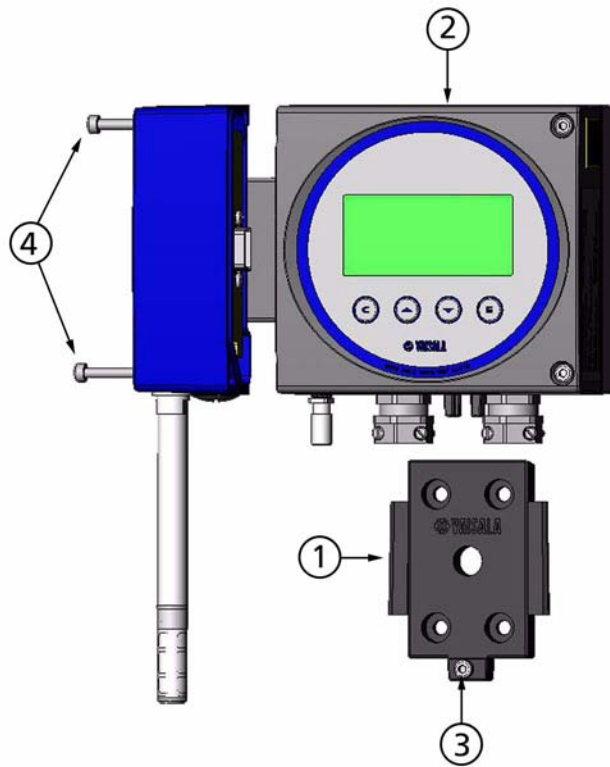

Figure 6 Transmitter Mounting

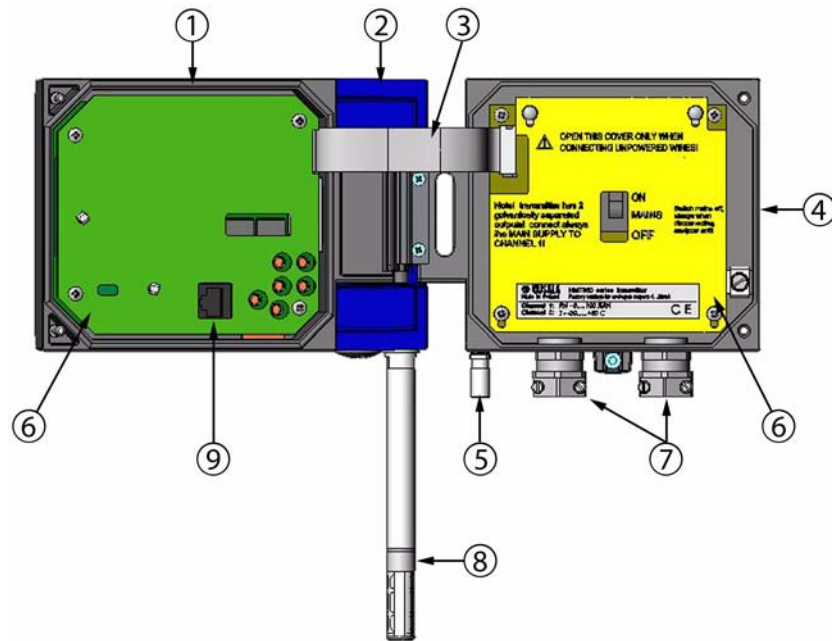

Figure 7 **Parts of the Transmitter**

The following numbers refer to [Figure 7 on page 24](#):

- 1 = Electronics unit
- 2 = Probe; including a part of the measurement electronics (for example, calibration memory)
- 3 = Flat cable
- 4 = Transmitter base
- 5 = Grounding terminal
- 6 = Protective covers
- 7 = Cable glands
- 8 = Probe
- 9 = RS232C connector

Probe Mounting

CAUTION

Do not unsolder and then resolder the probe cable from and to the printed board during installation.

Do not shorten or lengthen the probe cable.

These procedures may alter the humidity calibration of the transmitter.

HMP363 for Confined Spaces

The HMP363 is a small size ($\varnothing = 12\text{mm}$) general-purpose probe suitable for ducts and channels with the installation kit available from Vaisala.

The HMP363 provides for two measuring range options. The first probe version is equipped with a flexible cable and can be used when measuring in environments up to 80 °C. The second version is suitable for measuring in environments up to 120 °C.

Section [HMP363/365/367 Duct Installation Kit on page 26](#) shows mounting of HMP363/367 with the optional duct installation kit.

HMP363/365/367 Duct Installation Kit

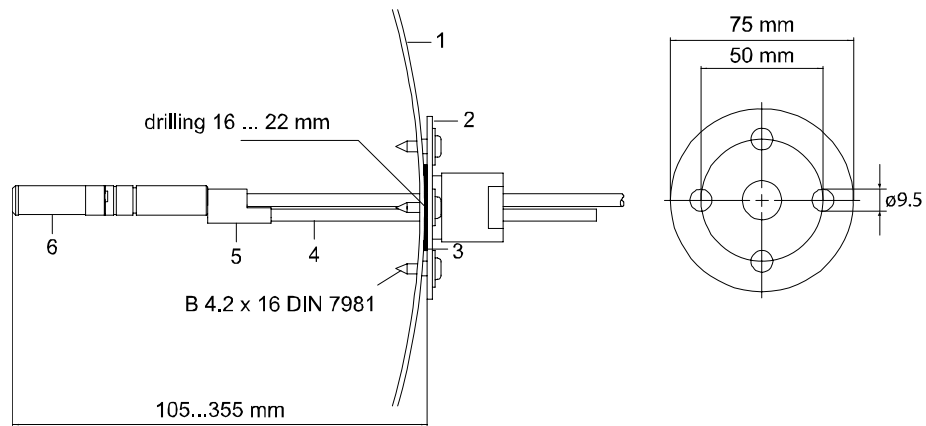

Figure 8 Installation of HMP363 Probe in Duct with Flange and Supporting Bar

The following numbers refer to [Figure 8 on page 26](#):

- 1 = Duct wall
- 2 = Flange
- 3 = Sealing ring
- 4 = Supporting bar
- 5 = Probe attaching part (to be fixed with supporting bar)
- 6 = RH probe

HMP364 for High-Pressure Applications

The probe is provided with a nut, a fitting screw and a sealing washer. Keep the fitting screw and the nut in place on the body of the probe during handling to prevent damage to the highly polished surface of the probe. Follow the instructions below to achieve a leak-tight assembly.

CAUTION

In pressurized processes it is essential to tighten the supporting nuts and screws very carefully to prevent loosening of the probe by the action of pressure.

1. Remove the fitting screw from the nut and the probe.
2. Fasten the fitting screw to the chamber wall with a sealing washer. Tighten the fitting screw into the threaded sleeve with a torque spanner. The tightening torque is 150 ± 10 Nm (110 ± 7 ft-lbs).
3. Insert the body of the probe into the fitting screw and tighten the nut manually to the fitting screw.
4. Mark both the fitting screw and the nut hex.
5. Tighten the nut a further 30° ($1/12$) turn or if you have a torque spanner tighten it with a torque of 80 ± 10 Nm (60 ± 7 ft-lbs).
6. Clean and grease the tightening cone of the fitting screw after every tenth detachment. Change the sealing washer every time the fitting screw is detached. Use high-vacuum grease, for example Dow Corning, or a similar grease.

NOTE

When retightening the nut after detachment the nut must be tightened without increased effort.

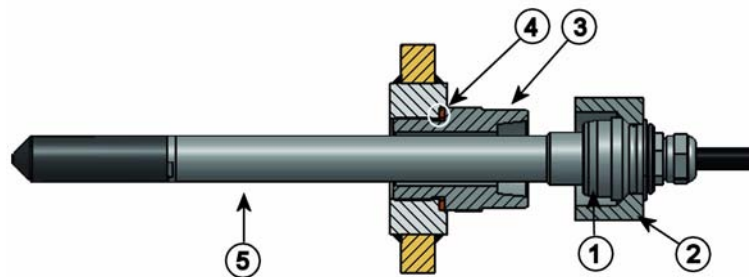

Figure 9 HMP364 Probe Mounting

The following numbers refer to [Figure 9 on page 27](#):

- 1 = Tightening cone
- 2 = Nut
- 3 = Fitting screw, M22×1.5 or NPT 1/2"
- 4 = Sealing washer
- 5 = Probe; $\varnothing 12$ mm

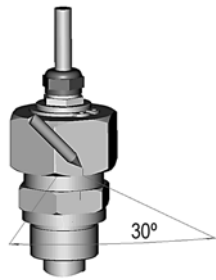

Figure 10 **Marking Nut and Fitting Screw**

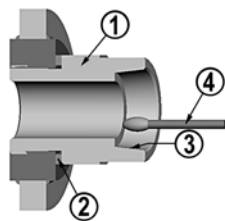

Figure 11 **Cleaning the Tightening Cone**

The following numbers refer to [Figure 11 on page 28](#):

- 1 = Fitting screw
- 2 = Sealing washer
- 3 = Tightening cone
- 4 = Clean cotton stick

CAUTION

In pressurized processes it is essential to tighten the supporting nuts and screws very carefully to prevent loosening of the probe by the action of pressure.

NOTE

When HMP364 is installed in a process with a pressure differing from normal atmospheric pressure, please enter the pressure value of the process (in bar_a) into the transmitter memory, see sections [PRES Setting Ambient Pressure for Calculations on page 56](#) and [Setting the Pressure for Calculations on page 46](#).

HMP365 for High Temperatures

HMP365 is installed similarly to the HMP363 probe but without the supporting bar. Refer to [HMP363/365/367 Duct Installation Kit on page 26](#) for more information on the duct installation kit for HMP365.

To avoid incorrect humidity readings, there must not be significant temperature differences between the inside and outside of the duct.

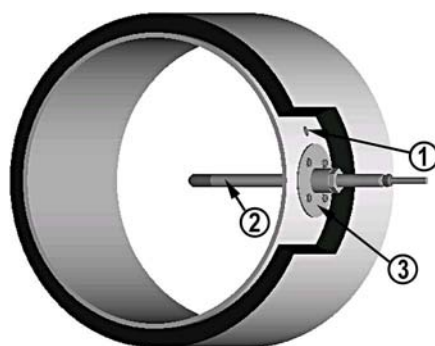

Figure 12 Mounting HMP365 Probe in Duct or Channel

The following numbers refer to [Figure 12 on page 29](#):

- 1 = A plugged hole for reference measurements
- 2 = Probe
- 3 = Mounting flange

HMP367 for High Humidities

The HMP367 is for environment where relative humidity is very high, near saturation.

Section [HMP363/365/367 Duct Installation Kit on page 26](#) shows mounting of HMP363/367 with the optional duct installation kit.

HMP368 for Pressurized Pipelines or Moisture in Liquids

Due to the sliding fit the HMP368 is easy to install into and remove from a pressurized process. The probe is especially suitable for measurements inside pipelines. See section [Installing the HMP368 Probe Through a Ball Valve Assembly on page 32](#).

CAUTION

In pressurized processes it is essential to tighten the supporting nuts and screws very carefully to prevent loosening of the probe by the action of pressure.

NOTE

When HMP368 is installed in a process with a pressure differing from normal atmospheric pressure, please enter the pressure value of the process (in bar_a) into the transmitter memory. See sections [PRES Setting Ambient Pressure for Calculations on page 56](#) and [Setting the Pressure for Calculations on page 46](#).

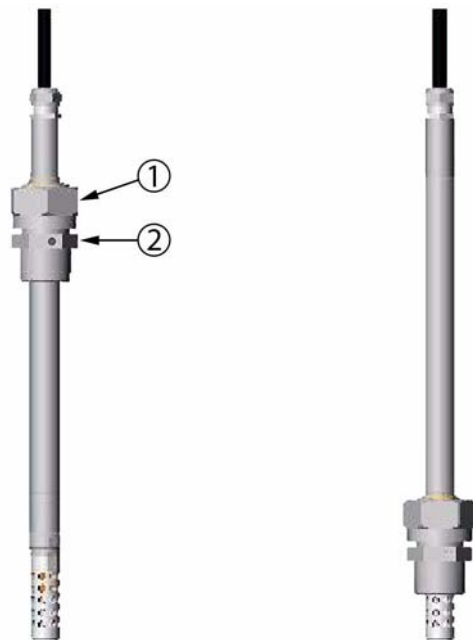

Figure 13 HMP368 Probe

The following numbers refer to [Figure 13 on page 30](#):

- 1 = Clasp nut, 24 mm hex nut
- 2 = Fitting body, 27 mm hex nut

The following two fitting body options are available:

- Fitting Body ISO1/2 solid structure
- Fitting Body NPT1/2 solid structure

Table 4 HMP368 Probe Dimensions

Probe Type	Probe Length	Adjustment Range
Standard	178 mm	120 mm
Optional	400 mm	340 mm

CAUTION

Take care not to damage the probe body. A damaged body makes the probe head less tight and may prevent it from going through the clasp nut.

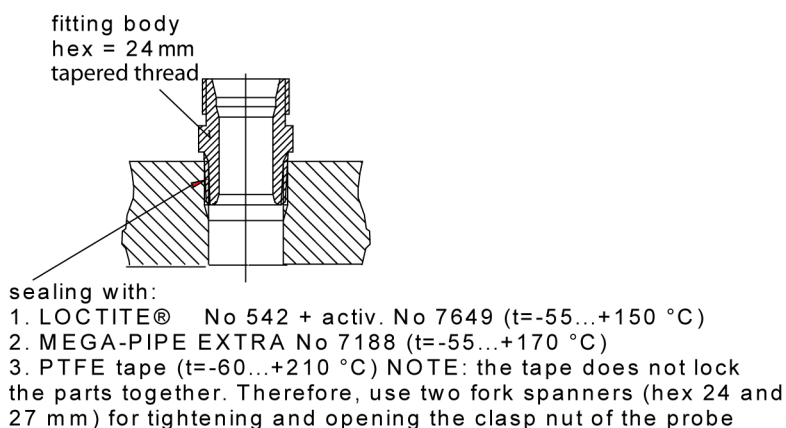

Figure 14 Sealing of Fitting Body into Process

Tightening the Clasp Nut

1. Adjust the probe to a suitable depth according to the type of installation.
2. Tighten the clasp nut first manually.
3. Mark the fitting screw and the clasp nut.
4. Tighten the nut a further 50 ... 60° (ca. 1/6 turn) with a fork spanner. If you have a suitable torque spanner, tighten the nut to 45 ± 5 Nm (33 ± 4 ft-lbs).

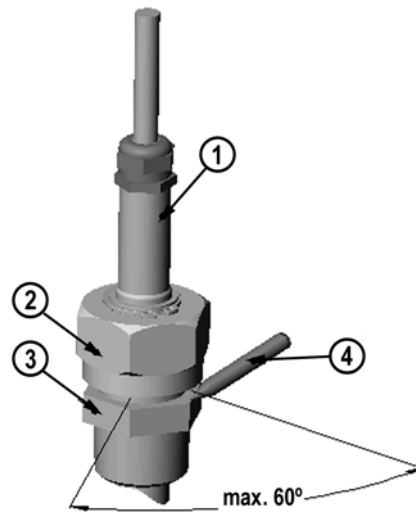

Figure 15 Tightening the Clasp Nut

The following numbers refer to [Figure 15 on page 32](#):

- 1 = Probe
- 2 = Clasp nut
- 3 = Fitting screw
- 4 = Pen

NOTE

Take care not to tighten the clasp nut more than 60° to avoid difficulties when opening it.

Installing the HMP368 Probe Through a Ball Valve Assembly

The ball valve installation kit (Vaisala order code: BALLVALVE-1) is preferred when connecting the probe to a pressurized process or pipeline. Use the ball valve set or a 1/2" ball valve assembly with a ball hole of $\varnothing 14$ mm or more. If you install the probe ($\varnothing 12$ mm) in a process pipe, please note that the nominal size of the pipe must be at least 1 inch (2.54 cm). Use the manual press handle to press the probe into the pressurized (< 10 bar) process or pipeline.

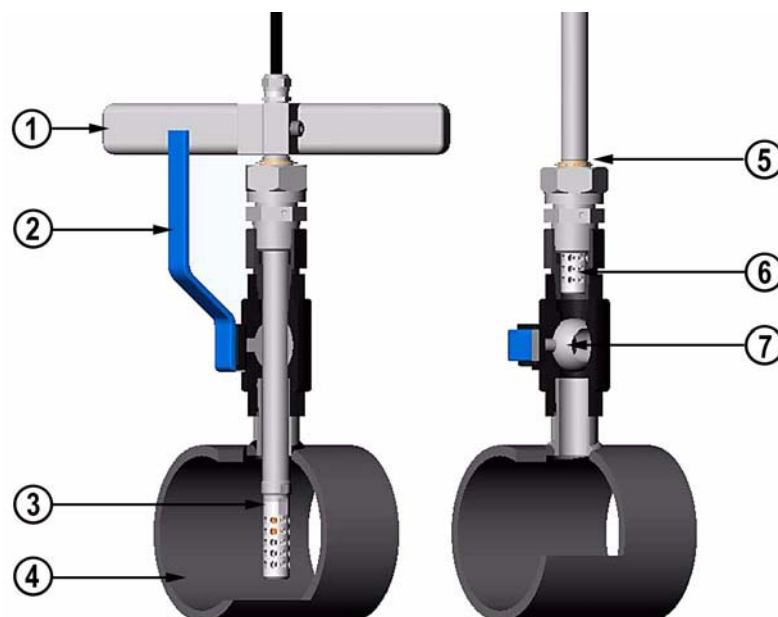

Figure 16 Installing the HMP368 Probe Through a Ball Valve Assembly

The numbers below refer to [Figure 16 on page 33](#):

- 1 = Manual press tool
- 2 = Handle of the ball valve
- 3 = Probe
- 4 = Process chamber/pipeline
- 5 = Groove on the probe indicating the upper adjustment limit
- 6 = Filter
- 7 = Ball of the ball valve

NOTE

The probe can be installed in the process through the ball valve assembly provided that the process pressure is less than 10 bar. This way, the process does not have to be shut down when installing or removing the probe. However, if the process is shut down before removing the probe, the process pressure can be max. 20 bar.

NOTE

When measuring temperature dependent quantities make sure that the temperature at the measurement point is equal to that of the process, otherwise the moisture reading may be incorrect.

Follow the steps below to install the HMP368 probe through a ball valve assembly. After the installation, the probe should be sitting in the process chamber or pipeline as shown in [Figure 16 on page 33](#).

1. Shut down the process if the process pressure is more than 10 bars. If the pressure is lower there is no need to shut down the process.
2. Close the ball valve.
3. Seal the threads on the fitting body; refer to [Figure 14 on page 31](#).
4. Attach the fitting body to the ball valve and tighten it.
5. Slide the clasp nut of the probe toward the filter, as far as it will go.
6. Insert the probe to the fitting body, and manually tighten the clasp nut to the fitting body.
7. Open the ball valve.
8. Push the probe through the ball valve assembly into the process. If the pressure is high, use the pressing handle that is provided with the probe. If you push the probe hard without using the handle, you may damage the cable.

Note that the probe must be pushed so deep that the filter is completely inside the process flow.
9. Mark the fitting screw and the clasp nut.
10. Tighten the clasp nut with a fork spanner a further 50 ... 60° (ca. 1/6 turn). If you have a suitable torque spanner, tighten the nut to max 45 ± 5 Nm (33 ± 4 ft-lbs). Refer to [Figure 15 on page 32](#).

NOTE

Take care not to tighten the clasp nut more than 60° to avoid difficulties when opening it.

If you wish to remove the probe from the process, note that you have to pull the probe out far enough. You cannot close the valve if the groove on the probe body is not visible.

Electrical Connections

Refer to local requirements regarding cabling, grounding and galvanic isolator or barrier connections.

WARNING

Connect the transmitter always via galvanic isolators or Zener barriers in hazardous environments.

WARNING

Be sure that the main power switch of the transmitter is set off before making any electrical installations in hazardous areas.

1. Open the transmitter cover and remove the protective cover of the transmitter base.
2. Thread the power supply wires through the cable gland, see [Figure 7 on page 24](#).
3. Connect the unpowered power supply wires to the connectors: Ch 1 (humidity) and Ch 2 (temperature). Both channels require an own power supply.
4. Replace the protective cover. Turn the transmitter on **ON** with the **ON/OFF** switch, see [Figure 24 on page 62](#).
5. Close the cover. The transmitter is ready for use.

NOTE

As Ch 1 is a main output, the transmitter does not operate if only Ch 2 is connected (Ch 2 is optoisolated from transmitter electronics).

When using the transmitter in hazardous locations, the use of galvanic isolators or barriers is essential. The following barrier & isolator are available in Vaisala: barrier No. 210664 (STAHL 9001/51-280-091-141) and galvanic isolator No. 212483 (STAHL 9160/13-11-11). Examples of connections and more information on installation in hazardous locations is given in section [Examples of Connections on page 41](#).

Installation in Hazardous Locations

US and Canadian Requirements

USA (FM): Wiring for intrinsically safe operation is shown in [Appendix B, Wiring for Intrinsically Safe Operation, FM, on page 95](#).

Canada (CSA): Wiring for intrinsically safe operation is shown in [Appendix C, Wiring for Intrinsically Safe Operation, CSA, on page 97](#).

European Requirements

CATEGORY 1 (Zone 0)

HMT360 has to be connected to Exia-certified associated apparatus with galvanic isolation, gas group IIB or IIC.

NOTE

If both analog outputs are in use, the Ch 1 (-) and Ch 2 (-) must be short circuited (see [Figure 19 on page 41](#)).

CATEGORY 2 or 3 (Zone 1 or 2)

HMT360 has to be connected either to a Zener barrier or galvanic isolator

NOTE

If both analog outputs are in use with a galvanic isolator, the Ch 1 (-) and Ch 2 (-) must be short circuited (see [Figure 19 on page 41](#)).

[Figure 17 on page 39](#) and [Figure 18 on page 40](#) present examples of galvanic isolators and Zener barrier connections (only Ch 1 connected).

Maximum Cable Resistance Calculation for the Barrier (Vaisala Order Code: 210664)

General specifications of HMT360:

Supply voltage	$U_{in} = 24 \text{ V (12 ... 35 V)}$
Maximum current	$I_{out} = 20 \text{ mA}$
Minimum operating voltage for HMT360	$U_{min} = 12 \text{ V (15 V with serial port)}$

Stahl 9001/51-280-091-141 (values taken from the specifications):

Rated operating voltage	$U_N = 20 \dots 35 \text{ V}$
Transmitter supply voltage	$U_S = U_N - 9.5 \text{ V, when}$ $U_N \leq 23.5 \text{ V}$ or $U_S = 14 \text{ V, when } U_N \geq 23.5 \text{ V}$
Maximum load	$R_L \leq 350 \Omega$

Calculation of the maximum cable length from barrier to transmitter:

Cable resistance (as an example) $R_{cable} = 0.085 \Omega/\text{m/core (} 2 \times 0.085 \Omega/\text{m/pair)}$

If assuming that the operating voltage would be $\geq 24 \text{ V}$, the maximum acceptable voltage drop U_{drop} in cables is:

$$U_{drop} = U_S - U_{min}$$

$$U_{drop} = 14 \text{ V} - 12 \text{ V} = 2 \text{ V}$$

We also know that:

$$I_{out} = 20 \text{ mA}$$

and that total resistance of the cable $R_{cabletot}$ is cable resistance R_{cable} multiplied with the total maximum length of the cables l_{max} :

$$R_{cabletot} = R_{cable} \times l_{max}$$

From these facts the following equation can be formed:

$$U_{\text{drop}} = R_{\text{cabletot}} \times I_{\text{out}}$$

$$2 = 2 \times 0.085 \, \Omega/\text{m} \times l_{\text{max}} \times 20 \, \text{mA}$$

$$l_{\text{max}} = 2 \, \text{V} / (20 \, \text{mA} \times 2 \times 0.085 \, \Omega/\text{m})$$

$$l_{\text{max}} = 588 \, \text{m} = 1930 \, \text{ft}, \text{ maximum cable length.}$$

NOTE

If longer cable length is required, use of the galvanic isolators is recommended if possible.

HMT360 Connected to a Galvanic Isolator

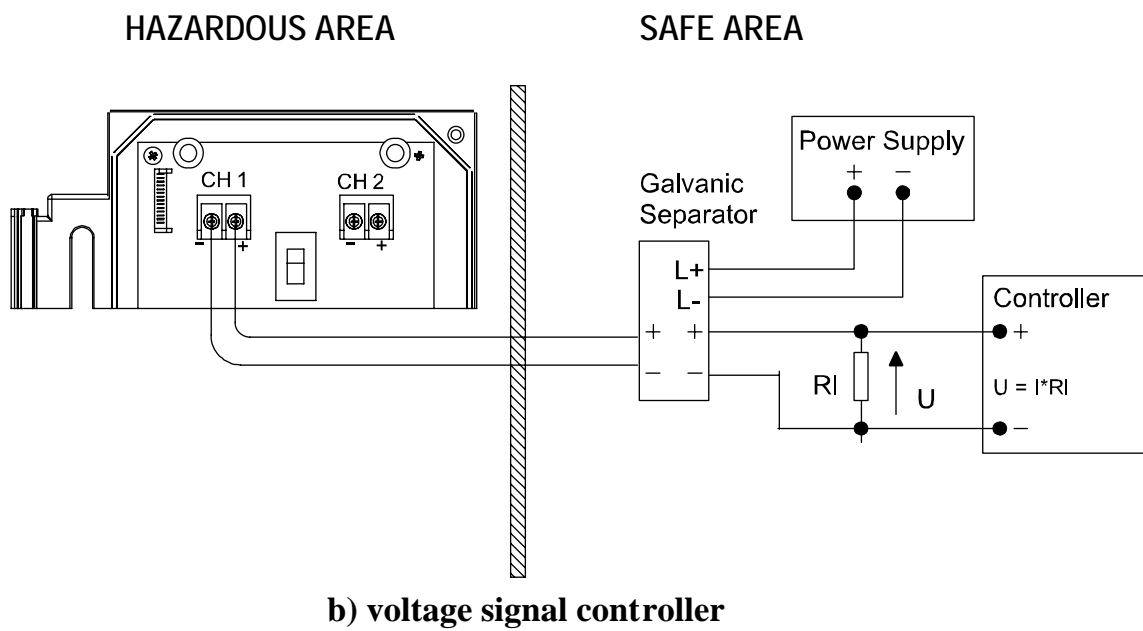
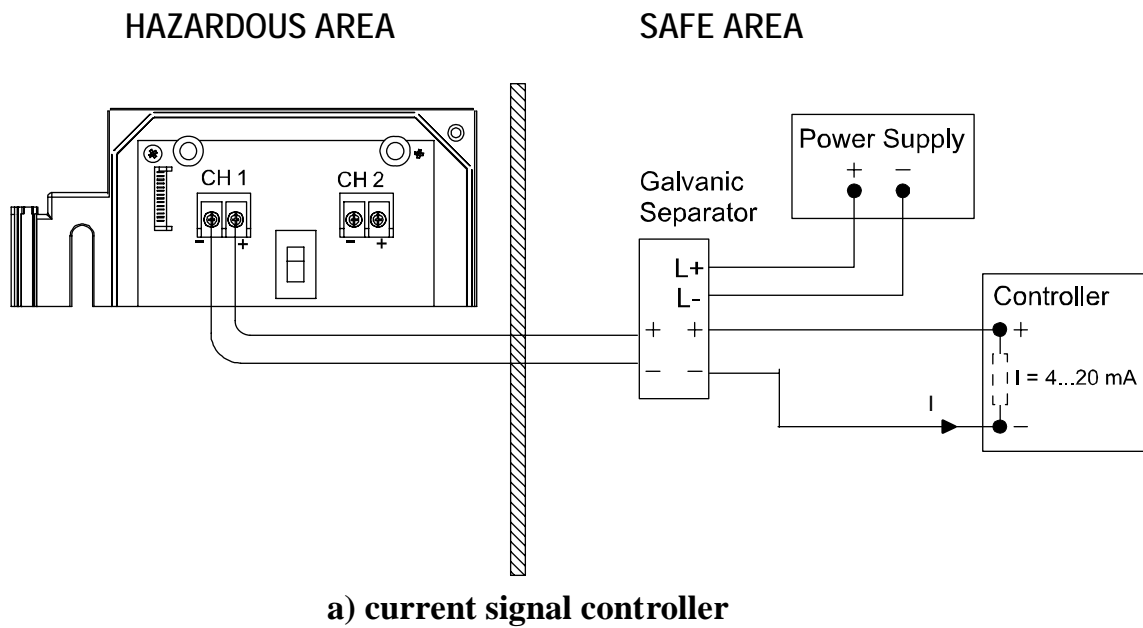
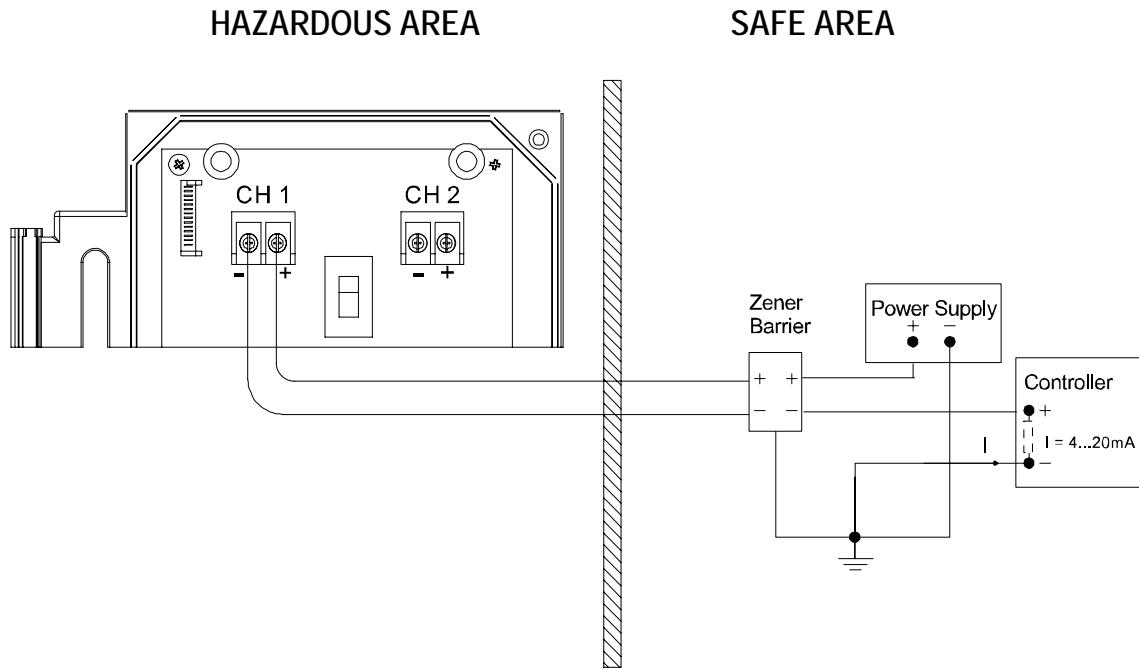
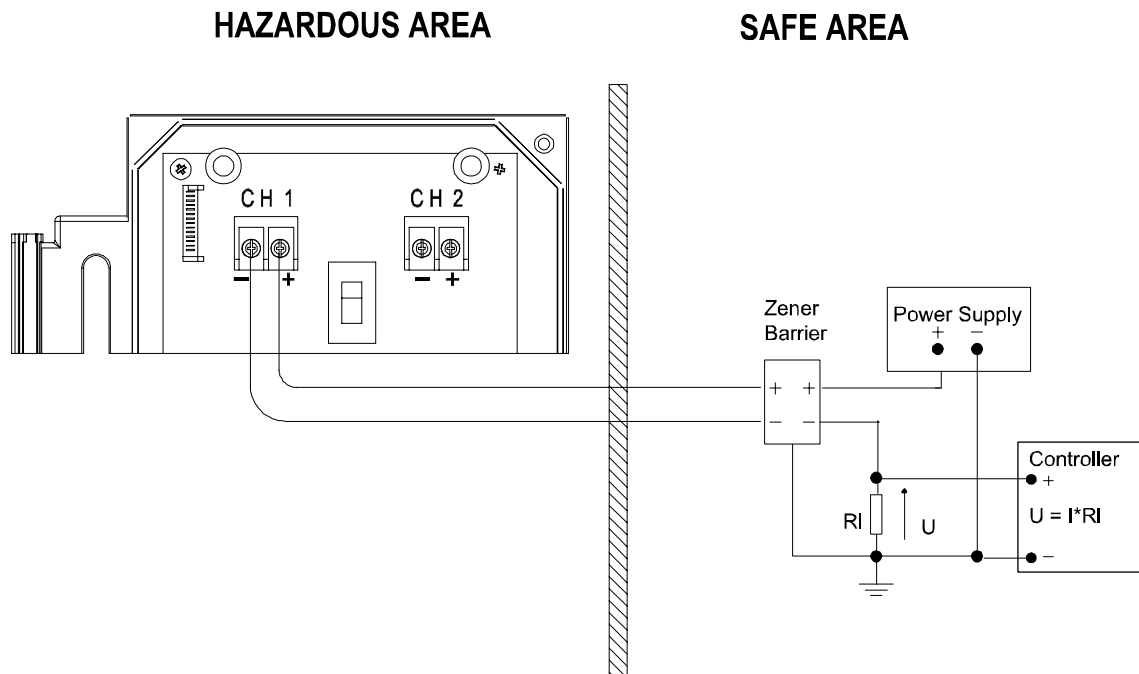

Figure 17 HMT360 Connected to Galvanic Isolator

HMT360 Connected to a Zener Barrier



a) current signal controller



b) voltage signal controller

Figure 18 HMT360 Connected to a Zener Barrier

Examples of Connections

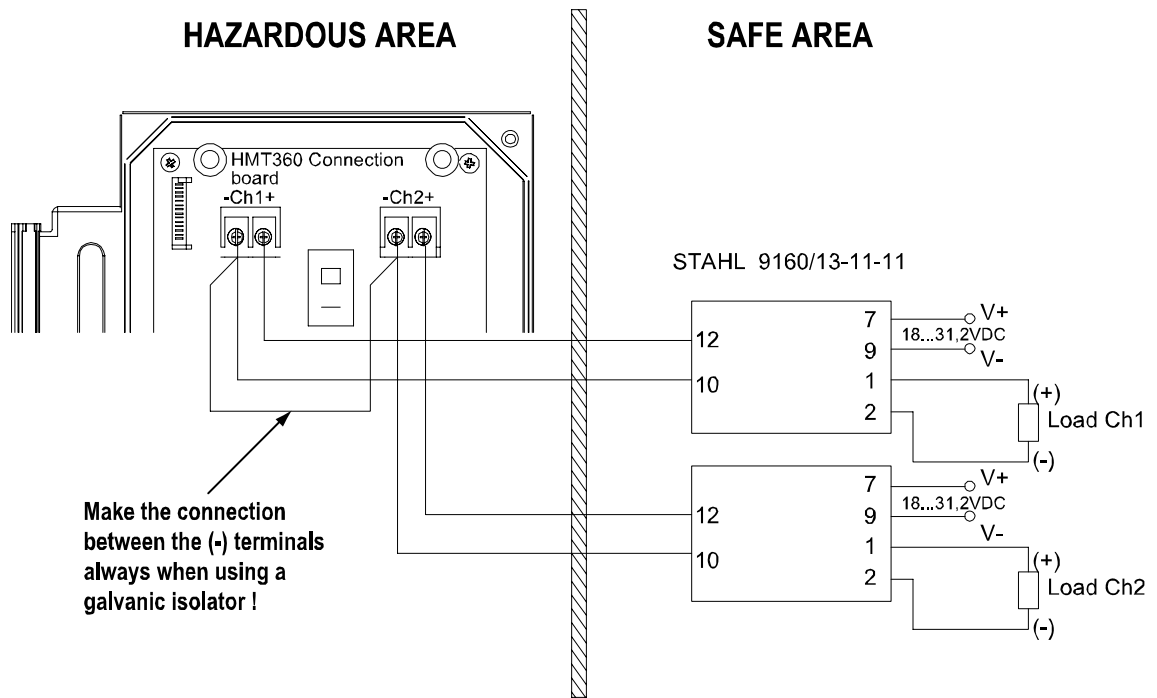

Figure 19 STAHL 9160/13-11-11 (Galvanic Isolator)

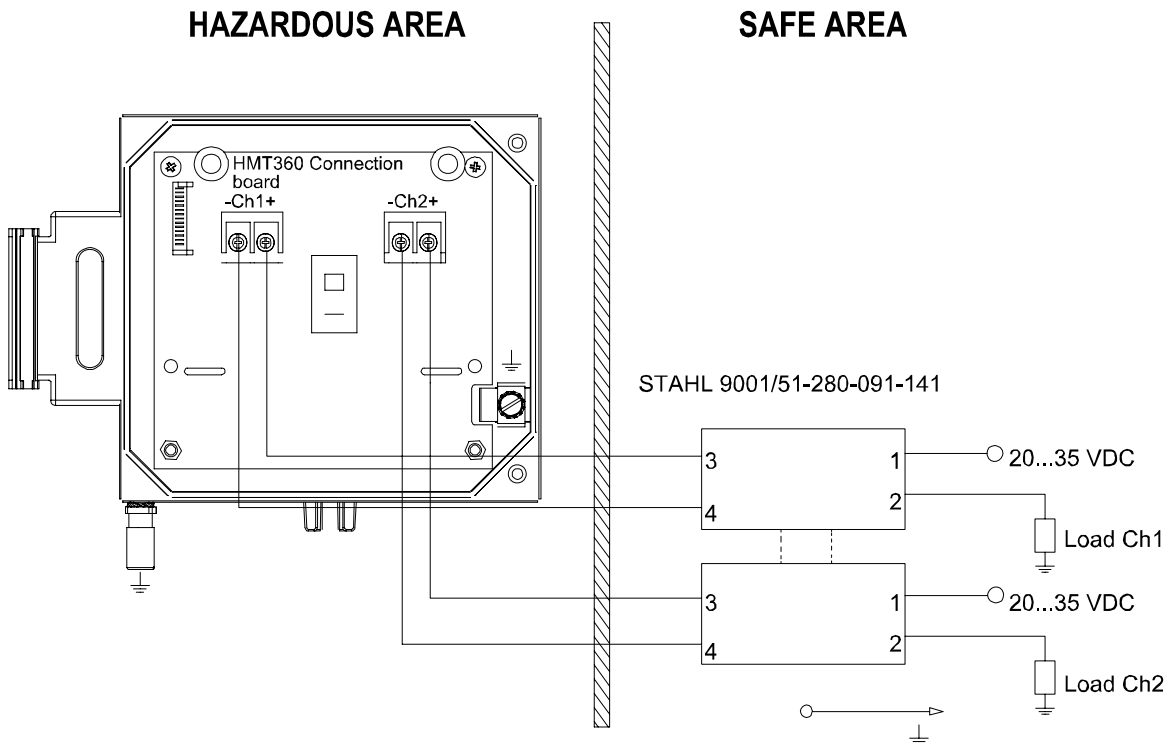

Figure 20 STAHL 9001/51-280-091-141 (Zener Barrier)

Grounding

When grounding the transmitter, follow the local requirements. Use at least 4 mm² grounding cable when grounding the transmitter or barrier. Note that the allowed resistance between barrier and system ground must be less than 1 ohm. Use ground terminal located inside or outside of transmitter [Figure 21 on page 42](#):

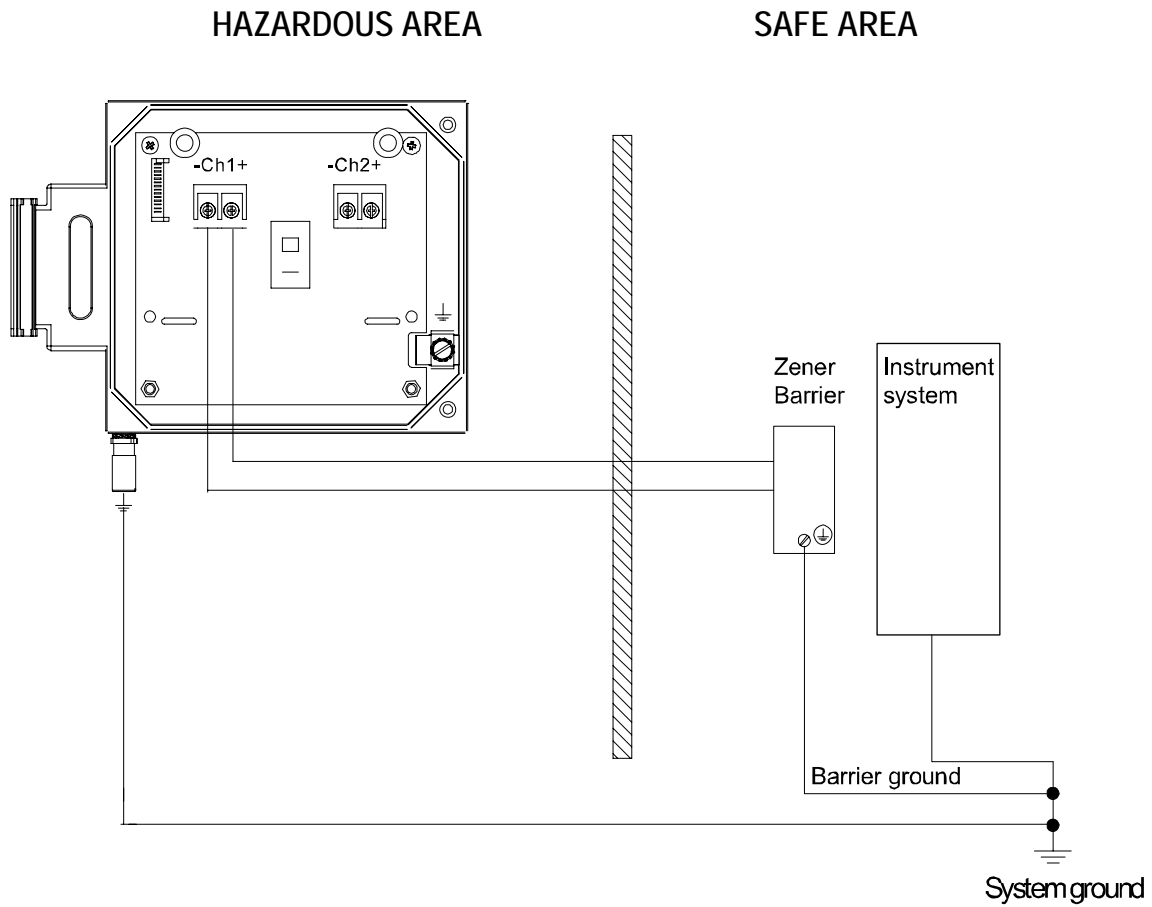

Figure 21 Grounding

CHAPTER 4

OPERATION

This chapter contains information that is needed to operate this product.

Local Interface

HMT360 transmitter has four pushbuttons located on the housing cover. The transmitter can be ordered either with or without a local display. The display/keypad commands (see [Display/Keypad Commands on page 46](#)) can be used to scale the outputs and select special output quantities (if the transmitter configuration includes special output quantities). The optional display shows the measurement results.

The keypad pushbuttons are indicated (from left to right) as **C**, **Up**, **Dn**, and **E** (see [Figure 22 on page 44](#)):

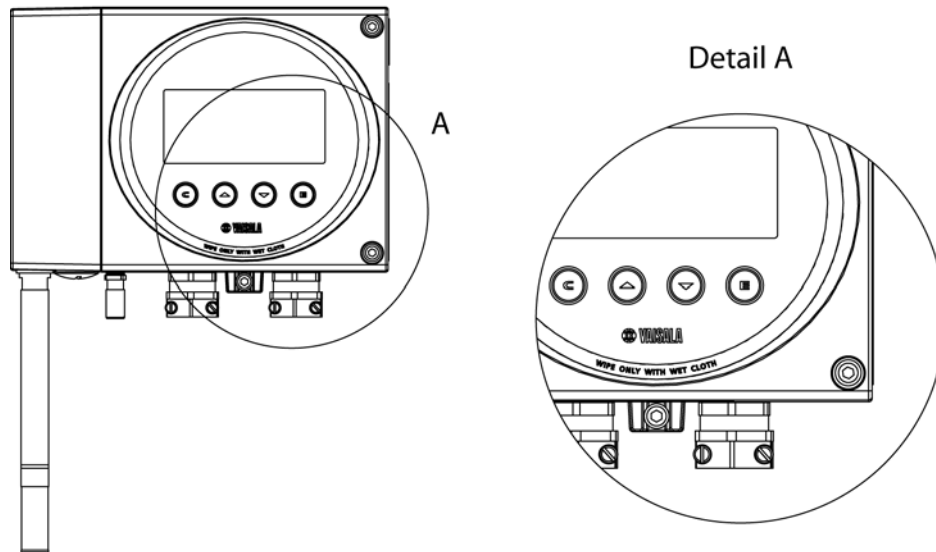

Figure 22 Local Display/Keypad Interface

Power ON/OFF

Open the transmitter cover and flip the internal power switch to position ON (up), see [Figure 24 on page 62](#).

WARNING

Avoid static discharge. Always use a wet cloth for wiping the display.

HMT360 with Display

Measurement readings appear on the display after switching power ON. The analog output signals can be read from the system or load resistor.

WARNING

Avoid static discharge. Always use a wet cloth for wiping the display.

HMT360 without Display

If the transmitter does not have a display, the red LED indicator on the cover indicates various phases of calibration and possible errors. In normal operation it is not lit. If the LED is lit and all calibration or test DIP switches are disabled, it is an indication of an internal error.

Otherwise, the LED indicates the following:

- LED blinking = calibration of the dry end (offset).
- LED lit = calibration of the wet end (gain).

NOTE

If calibration is concluded but DIP switch settings are not restored, the LED indicator keeps blinking.

DIP Switch Functions

The table below is also printed on the protection board:

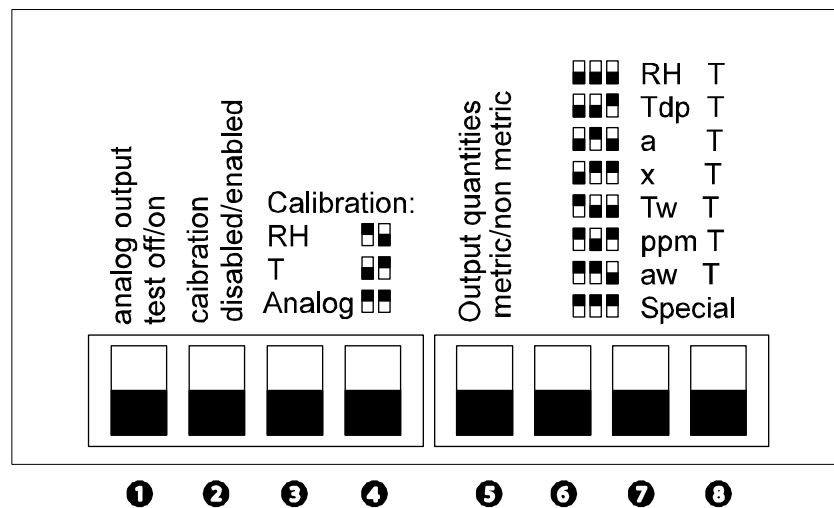

Figure 23 DIP Switch Functions

1: Analog output test on/off

If you turn the switch to on position (up), you can force the outputs to states 4 mA, 12 mA and 20 mA by pressing buttons **Up** and **Down** on the cover. Outputs return to normal mode when switch is turned down.

2: Calibration Disabled/Enabled

The EEPROMs are write protected. If this switch is in the disabled position (down), it does not allow any calibrations or scalings.

NOTE

Keep this switch always in the disabled position during normal use of the transmitter.

3 and 4: Calibration rh, t, analog

With these combinations you can perform relative humidity, temperature or analog output calibrations with a multimeter or with the transmitter display unit. Turn the DIP switches to the desired position according to the table printed on the protective cover.

5: Output quantities

Determines whether the output units are metric (down) or non-metric.

6, 7 and 8: Select output quantities

With the three DIP switches on the right, you can select the output quantities according to the table printed on the right side of the protective cover. Note that only the ordered quantities can be selected. The special option gives you the choice of setting any ordered quantity to each channel.

NOTE

Always restore the DIP switch settings after having tested the analog outputs or performing the calibration.

Display/Keypad Commands

NOTE

[Chapter 6, Calibration and Adjustment, on page 61](#) describes separately display/keypad commands for calibration and adjustment.

Setting the Pressure for Calculations

In humidity transmitters, ambient pressure is used for the mixing ratio and wet bulb calculations.

To modify the pressure settings, turn the internal **Calibration Enabled/Disabled** DIP switch of the transmitter to position **Enabled** (up). Press button **C** on the display cover: text "SCAL" appears on the display. Then press button **E** until the following display appears (the numeric value is always the existing setting, in this example 1.0):

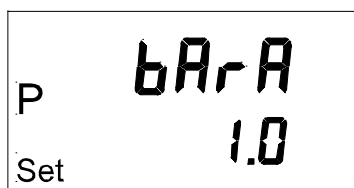

Adjust the pressure reading with buttons **Up** and **Dn**. Acknowledge the value with button **E**. To complete the pressure setting, turn the dip switch back to position disabled (down).

See the pressure conversion table on page [Table 6 on page 56](#).

Selecting Output Quantities

Upper Half of Display

To modify the displayed quantity, turn the **Calibration Enabled/Disabled** DIP switch of the transmitter to position **Enabled** (up). Select the required quantity with button **Up** on the display cover, and acknowledge the value with button **E**. To complete the selections, turn the DIP switch back to position disabled (down).

Character	Quantity	Abbreviation	Availability	Metric Unit	Nonmetric Unit
0	relative humidity	RH	A, D	%RH	%RH
1	temperature	T	A, D, F, H	°C	°F
2	dewpoint temperature	Td	D	°C	°F
3	absolute humidity	a	D	g/m ³	gr/ft ³
4	mixing ratio	x	D	g/kg	gr/lb
5	wet bulb temperature	Tw	D	°C	°F
6	mass concentration of water	ppmw	H	ppm _w	ppm _w
7	water activity	aw	H, F	0 ... 1	0 ... 1
8	relative humidity of saturation	RS	H	%RS	%RS
9	saturation temperature	Ts	H	°C	°F

The characters used to indicate availability in the table above:

- A = Available for HMT360 standard version
- D = Available for HMT360 with optional calculations
- F = Available for HMT360 Moisture and Temperature in oil transmitter
- H = Available for HMT360 Moisture and Temperature in Jet Fuel transmitter

Lower Half of Display

The output quantities metric/non metric DIP switch can be used to select between °C and °F.

It is possible to check the pressure setting of the transmitter by pressing button **Dn**. To return to the temperature reading, press button **Dn** again.

Selecting Analog Outputs

You can select the output quantities for channels 1 and 2 by turning the **Calibration Enabled/Disabled** DIP switch of the transmitter to position **Enabled** (up) and the three output selection DIP switches to position special (all up).

Press button **C** on the display cover: text "SCAL" appears on the display. Then press button **E** until the following display appears:

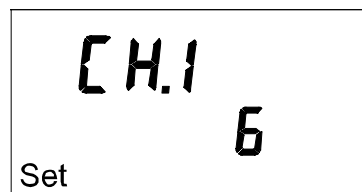

The characters on the second line of the display in this menu correspond to the quantities according to the table in section [Selecting Output Quantities on page 47](#).

Select the quantity for Ch 1 with buttons **Up** and **Dn** and acknowledge the selection with button **E**.

If the transmitter is equipped with two analog channels, select the quantity for Ch 2 in the same way, for example:

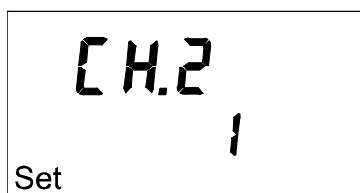

Press button **C** to exit the display command mode or continue by setting the pressure.

NOTE

Remember to restore the DIP switch settings.

Scaling Analog Outputs

Turn the internal **Calibration Enabled/Disabled** DIP switch of the transmitter to upward position (on). Press button **C** on the display cover and a text similar to the following appears:

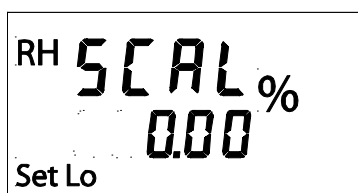

Numbers on the second line indicate the low end scaling of Ch 1 currently stored in the transmitter memory. The text "Set Lo" on the lower left corner indicates that you can now change the low end scaling with buttons **Up** and **Dn**. Acknowledge the value with button **E** and a text similar to the following appears:

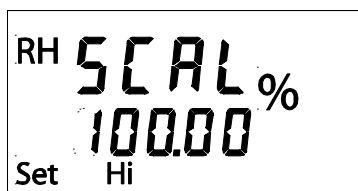

Numbers on the second line indicate the high end scaling of Ch 1. The text "Set Hi" on the lower left-hand corner indicates that you can now change the high end scaling with buttons **Up** and **Dn**. Acknowledge with button **E**.

If there is another channel available, the display shifts to the scaling menu of Ch 2. You can now scale the analog outputs for the Ch 2 in the same way as described above.

Press button **C** to exit the display command mode or continue by selecting the output quantities. This menu starts automatically after the scaling menu only if the output selection DIP switches are on the position special (all up) from the beginning.

NOTE

Remember to restore the DIP switch settings.

Serial Interface

WARNING

The serial interface **MUST NOT** be used in hazardous areas.

Use the serial interface for calibration and testing purposes in safe areas only. Always use the serial interface cable (optional accessory, Vaisala order code: 25905ZZ). Connect one end of the cable to the serial port of your computer and the other to the connector marked "RS232C" on the electronics unit of the transmitter (see [Figure 7 on page 24](#)).

NOTE

With serial communication the current consumption increases approximately to 7 mA and the transmitter is not able to operate with 4 mA. Therefore, it is recommended to use serial communication only temporarily for changing settings or for calibrating the transmitter in a safe area. With serial port, the minimum supply voltage is 15 VDC.

NOTE

The transmitter incorporates a serial interface detector. However, not all terminals or PC serial ports (for example, optoisolated or ports not meeting RS232C standards) recognize this standard. If the communication is not possible via a serial interface, use a forced activation by pressing simultaneously buttons **Up** and **E** on the transmitter cover. To deactivate the forced activation, press these buttons again or reset the transmitter. If the transmitter does not receive any commands for half an hour, it automatically closes the serial communication.

Serial Communication Settings

Table 5 Serial Communications Settings

Parameter	Value
bauds	2400
parity	none
data bits	8
stop bits	1

CAUTION

When using the serial interface, be sure that power supply and serial interface are not connected to the same ground (use a floating power supply or hand-held serial interface device).

To start issuing commands, make sure that HMT360 is connected to a serial port of your computer and that the terminal session is open. Issue commands by typing them on your computer according to the following instructions. In these commands, <cr> stands for pressing Enter (on your computer keyboard).

Setting the Analog Outputs

ASEL Selecting Analog Outputs

Syntax: **ASEL** [xxx yyy]<cr>

where

xxx = Quantity of Ch 1

yyy = Quantity of Ch 2

Turn the internal DIP switch **Calibration Enabled/Disabled** to position **ON** before the selecting the analog outputs and return it to position **OFF** after making the selection. Output quantities and their abbreviations are listed in the following table:

Character	Quantity	Abbreviation	Availability	Metric Unit	Nonmetric Unit
0	relative humidity	RH	A, D	%RH	%RH
1	temperature	T	A, D, F, H	°C	°F
2	dewpoint temperature	Td	D	°C	°F
3	absolute humidity	a	D	g/m ³	gr/ft ³
4	mixing ratio	x	D	g/kg	gr/lb
5	wet bulb temperature	Tw	D	°C	°F
6	mass concentration of water	ppmw	H	ppm _w	ppm _w
7	water activity	aw	H, F	0 ... 1	0 ... 1
8	relative humidity of saturation	RS	H	%RS	%RS
9	saturation temperature	Ts	H	°C	°F

Example:

```
>asel rh t<cr>
Ch1 RH lo : 0.00 %RH
Ch1 RH hi : 100.00 %RH
Ch2 T lo: -40.00 'C
Ch2 T hi: 100.00 'C
>
```

S Scaling Analog Outputs

Syntax: **S***zz aa.a bb.b*<cr>

where

zz = Quantity (RH, T, Td, x, a, Tw, ppm, aw, RS, Ts)

aa.a = Lower limit of the quantity

bb.b= Upper limit of the quantity

Turn the internal DIP switch **Calibration Enabled/Disabled** to position **ON** before the scaling the analog outputs and return it to position **OFF** after scaling.

Example:

```
>srh 0 100<cr>
RH lo: 0.00 %RH
RH hi: 100.00 %RH
>
```

Adjustment Commands

Turn the internal DIP switch **Calibration Enabled/Disabled** to position **ON** before the adjustment and return it to position **OFF** after the adjustment.

CRH Relative Humidity Adjustment

NOTE

Read also the calibrator, for example HMK15, manual and refer to page 19 of that manual for more detailed instructions on salt bath calibration and adjustment.

Syntax: **CRH**<cr>

The transmitter asks and measures relative humidity and calculates the calibration coefficients.

Example:

```
>crh<cr>
RH : 1.82 1. ref ? 0<cr>
  Press any key when ready ...<cr>
RH : 74.222 2. ref ? 75<cr>
OK
>
```

The OK indicates that the adjustment was successful.

CT Temperature Adjustment

Syntax: **CT**<cr>

The transmitter asks and measures temperature readings and calculates the calibration coefficients.

Example:

```
>ct<cr>
T : 0.811 1. ref ? 0.5<cr>
  Press any key when ready ...<cr>
T : 99.122 2. ref ? 99.5<cr>
OK
>
```

The OK indicates that the adjustment was successful. When performing one-point adjustment press only Enter for the second reference.

Output Commands

ITEST Testing Analog Outputs

NOTE

Before giving command **ITEST**, reset the transmitter with command **RESET**, see section [RESET Transmitter Reset on page 57](#).

Syntax: **ITEST** *aa.aaa bb.bbb*<cr>

where

aa.aaa = Current value to be set for Ch 1 (mA)

bb.bbb = Current value to be set for Ch 2 (mA)

This command outputs the current value of each channel and the corresponding control signal of the digital-to-analog converter.

Example:

```
>itest 8 12<cr>
8.00000 403 12.00000 7DF
>itest<cr>
7.00150 30A 11.35429 73E
>
```

The set current values remain valid until you issue the command **ITEST** without readings or reset the transmitter. With this command the desired outputs of the transmitter are shown.

NOTE

When outputting low currents from Ch 1, remember to remove RS232C-cable while reading the current output, because of the increased current consumption for using RS port.

SEND Outputting Measurement Values

Syntax: **SEND**<cr>

This command outputs the measured values in one point.

R Activating Continuous Output

Syntax: **R**<cr>

With the command **R** the transmitter outputs measured values continuously.

S Stopping Continuous Output

Syntax: **S**<cr>

The continuous outputting is stopped with the command **S**. If outputting is active, this command is not echoed.

INTV Setting Output Interval

Syntax: **INTV** *n xxx*<cr>

where

n = 1 ... 255

xxx = S, MIN or H

Sets the output interval when the transmitter outputs measurement readings. The time interval is used when the continuous output is active.

Example, the output interval is set to 10 minutes:

```
>intv 10 min<cr>
Output interval: 10 MIN
>
```

PRES Setting Ambient Pressure for Calculations

Syntax: **PRES** *aaaa.a*<cr>

where

aaaa.a = Pressure (bar_a)

Turn the internal DIP switch **Calibration Enabled/Disabled** to position **ON** before setting the pressure and return it to position **OFF** after making the setting.

Example:

```
>pres 12<cr>
Pressure      :      12.0 bara
>
```

Table 6 Pressure Conversion Chart

	FROM	hPa/mbar	mmHg/Torr	inHg	atm	bar	psi
	hPa/ mbar	1	1.333224	33.86388	1013.25	1000	68.94757
TO	mmHg/ Torr	0.7500617	1	25.40000	760	750.0617	51.71493
	inHg	0.02952999	0.03937008	1	29.921	29.52999	2.036021
	atm	0.00098692	0.00131597	0.033422	1	0.98692	0.068046
	bar	0.001	0.001333224	0.03386388	1.01325	1	0.06894757
	psi	0.01450377	0.01933678	0.4911541	14.6962	14.50377	1

Example:

$$29.9213 \text{ inHg} = 29.9213 \times 33.86388 = 1013.25 \text{ hPa / mbar}$$

NOTE

Conversions from mmHg and inHg are defined at 0 °C.

FILT Output Filtering

Syntax: **FILT** *a.aaa*<cr>

where

a.aaa = 0.1 ... 1

1 = No filtering

0.5 = Average of last two measurements

0.1 = Average of ca. 16 measurements

This command sets the measurement result filtering.

Example:

```
>filt 1<cr>
Filter          : 1.0000
>filt 0.5<cr>
Filter          : 0.5000
>filt 0.1<cr>
Filter          : 0.1000
>
```

Resetting the Transmitter

RESET Transmitter Reset

Syntax: **RESET**<cr>

This command resets the device.

CHAPTER 5

MEASURING AT OVERPRESSURE

This chapter provides you with important information concerning measurement in conditions with pressure higher than the normal atmospheric pressure.

The probes HMP364 and HMP368 are designed for humidity measurement at overpressure. The maximum measurement pressures depend on the probe as follows:

- | | |
|---------|---|
| HMP364: | 0 ... 100 bar (10 MPa), for pressurized rooms and processes, probe is provided with a nut, fitting screw and sealing washer |
| HMP368: | 0 ... 40 bar (4 MPa), for pressurized pipelines, ball valve set available |

The accuracy of the dewpoint measurement is affected by pressure in the measurement chamber. The actual pressure in the sampling cell is required to be set to the transmitter by using the serial line command **PRES** (see section [PRES Setting Ambient Pressure for Calculations on page 56](#) or by using the keypad commands, see section [Setting the Pressure for Calculations on page 46](#)).

Pressure Regulator Recommended

When sampling pressurized processes exceeding the maximum measurement pressure of the probe, the pressure in the measurement chamber must be regulated to the acceptable level or below. It is recommended to use pressure regulator before the measurement chamber to prevent remarkable pressure variations.

CHAPTER 6

CALIBRATION AND ADJUSTMENT

This chapter contains instructions for checking the calibration and adjusting this product.

In this User's Guide the term "calibration" refers to comparing the device's reading against a reference concentration. "Adjustment" refers to changing the device's reading to correspond to the reference concentration.

Calibration Interval

HMT360 is calibrated as shipped from the factory. Typical calibration interval is one year. In demanding applications it may be advisable to make the first calibration check earlier.

Factory Calibration and Adjustment

The device (or the probe only) can be sent to Vaisala Service Centers for calibration and adjustment, see [Vaisala Service Centers on page 75](#) for contact information.

User Calibration and Adjustment

Calibration and adjustment is carried out by using the keypad or by using serial commands. The following additional equipment is needed in adjustment of HMT360:

- a power supply for the channel(s) to be calibrated (12 ... 24 VDC),
- a multimeter for HMT360 without a display, and
- the calibrated references.

First, the electronics unit is removed from the transmitter base to perform the calibration and adjustment in safe area. Second, the power supply and a multimeter is connected to the electronics unit according to the following instructions.

Removing the Electronics Unit

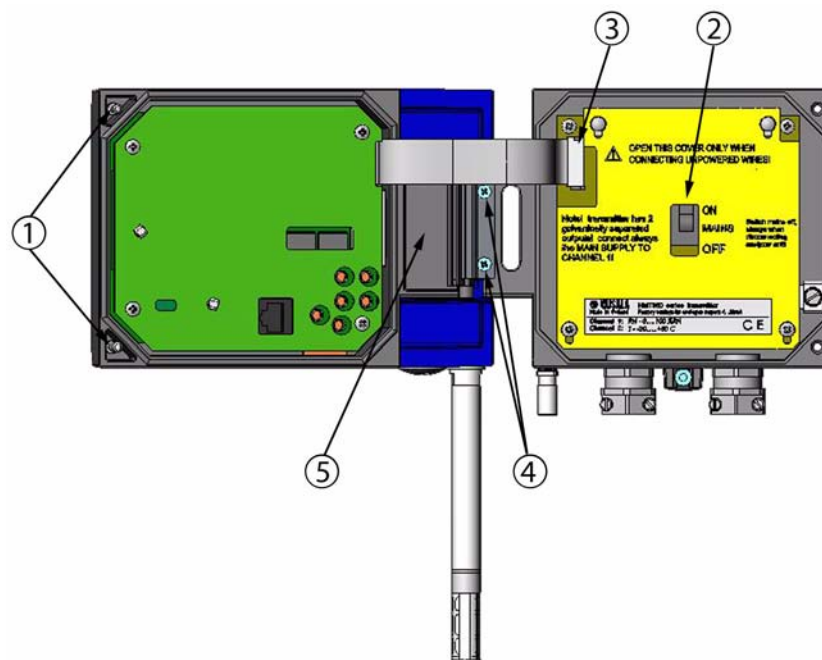

Figure 24 Detaching the Electronics Unit with Probe for Calibration and Adjustment

1. Unfasten the screws and open the cover.
2. Switch the transmitter off with the **ON/OFF** switch.

3. Disconnect the flat cable by lifting it carefully, for example with a screwdriver.
4. Remove the two screws holding the hinge support. Remove the hinge support.
5. Turn the electronics unit slightly upwards to release it from the hinges. Leave the transmitter base with the cable connections on place. When putting the electronics unit back to place, attach the upper hinge first. Remember to attach the hinge support.

Connections

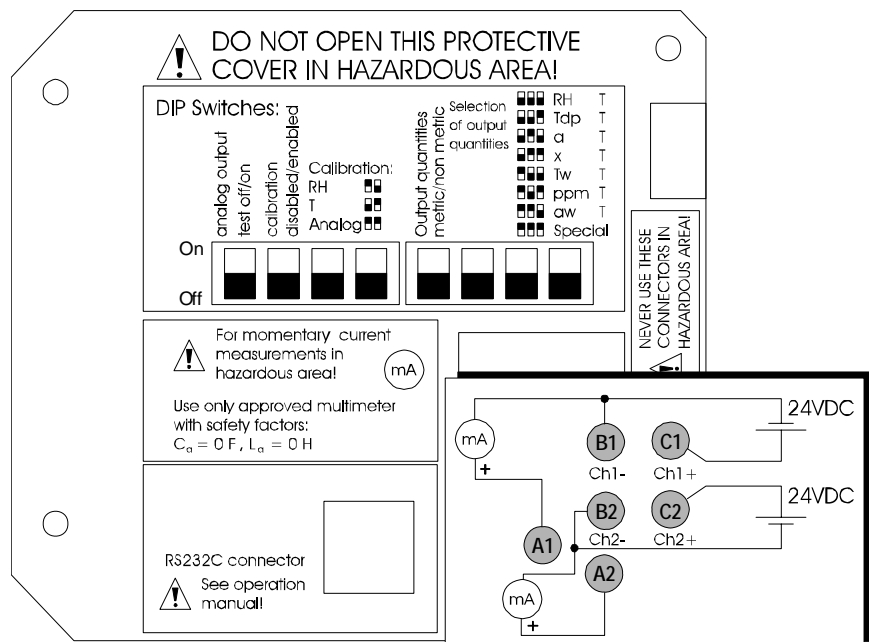

Figure 25 Connecting Power Supply and Multimeter for Calibration

1. Connect a power supply (12 ... 24 VDC, with a serial port the minimum supply voltage is 15 VDC) to the terminals B1 (-) and C1 (+) (Ch 1) with banana plugs, see [Figure 25 on page 63](#).
2. Connect the multimeter in series with the supply, B1 (-) and A1 (+).
3. Follow the same procedure with Ch 2 using the terminals B2 (-) and C2 (+). When calibrating both channels at the same time, use two galvanically separated power supplies.

You can now calibrate or check the humidity and temperature or the analog outputs according to the instructions given in this chapter.

If the current measurement is needed in a hazardous area, the multimeter is connected to the terminals A1/A2 (+) and B1/B2 (-). Use only an approved multimeter.

WARNING

The power supply connectors (C1 and C2) **MUST NOT** be used in hazardous areas. For calibration and adjustment in a hazardous area use only an approved multimeter, which fulfills the safety factors printed on the protective cover.

Calculating Correspondence of Current Values and Output Quantities

When using HMT360 without a display, calibration and adjustment is carried out by using a multimeter. Use the following equations to calculate the current values corresponding to the reference output quantities.

$$I = 4 \text{ mA} + 16 \text{ mA} \cdot \frac{Q_{\text{ref}} - Q_{\text{min}}}{Q_{\text{max}} - Q_{\text{min}}}$$

where

Q_{ref} = Reference value of the calibrated quantity

Q_{min} = Reference value of the calibrated quantity

Q_{max} = Value corresponding to 20 mA

Example 1:

Relative humidity scaling 0 ... 100 %RH, reference 11.3 %RH:

$$I = 4 \text{ mA} + 16 \text{ mA} \cdot \frac{11.3 \text{ \%RH} - 0 \text{ \%RH}}{100 \text{ \%RH} - 0 \text{ \%RH}} = 5.808 \text{ mA}$$

Example 2:

Temperature scaling -40 ... +120 °C, reference 22.3 °C:

$$I = 4 \text{ mA} + 16 \text{ mA} \cdot \frac{22.3^\circ \text{C} - 40^\circ \text{C}}{120^\circ \text{C} - 40^\circ \text{C}} = 10.230 \text{ mA}$$

Relative Humidity Adjustment

Automatic Two-Point Adjustment (Only with HMT360 with Display)

The automatic adjustment procedure is a user friendly way to adjust the HMT360 with salt solutions; you do not have to feed the reference values to the HMT360. The transmitter displays the accurate value based on the measured temperature and the Greenspan table stored into the transmitter memory. The display chart of the adjustment procedure is presented in [Figure 26 on page 66](#).

- Set the internal DIP switch **Calibration Enabled/Disabled** to position **ON** and select RH calibration by using switches 3 and 4 (see section [DIP Switch Functions on page 45](#)).
- Remove the filter and insert the probe into a measurement hole of the LiCl salt chamber in the humidity calibrator. Acknowledge by pressing button **E**. Alternatively select the 0.1 (humidity in nitrogen) with buttons **Up** and **Dn**. Acknowledge with button **E**.
- The transmitter remains to wait for the process stabilization (10 ... 15 min) and then stores the correction.
- Insert the probe into a measurement hole of the NaCl salt chamber in the humidity calibrator. Acknowledge by pressing button **E**. Alternatively you can select K₂SO₄ value with buttons **Up** and **Dn**.
- The transmitter remains to wait for the stabilization and then stores the correction. The text "Cal Pass" is displayed after the adjustment is performed.

NOTE

Remember to restore the DIP switch settings.

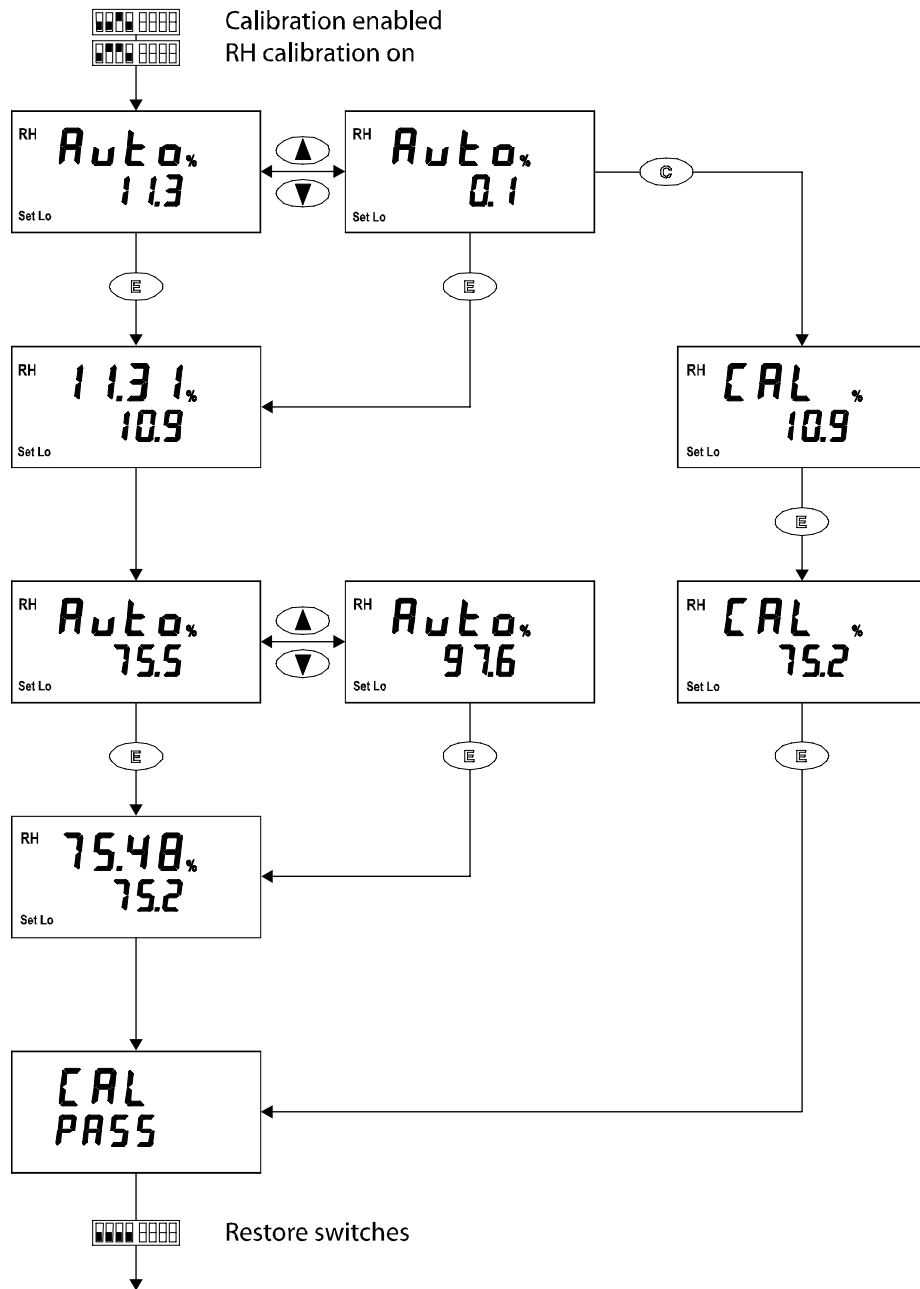

Figure 26 Display Chart of the Automatic Adjustment Procedure

Manual Adjustment

Low End Adjustment

NOTE

If you use serial commands, please refer to section [Adjustment Commands on page 53](#).

1. Remove the filter and insert the probe into a measurement hole of the dry end reference chamber (for example LiCl: 11 %RH) in the humidity calibrator.
2. Remove the filter and insert the probe into a measurement hole of the dry end reference chamber (for example LiCl: 11 %RH) in the humidity calibrator.
3. Set the internal DIP switch **Calibration Enabled/Disabled** to position **ON** and select RH calibration by using switches 3 and 4 (see section [DIP Switch Functions on page 45](#)).
4. Press button **C** (*HMT360 without display*: press button **E**) to ignore the automatic adjustment procedure. The humidity reading measured by the transmitter appears on the display and on the lower left corner you can see the text "Set Lo". If the transmitter has no display, the LED indicator is blinking.
5. According to the calibrator used, wait at least 10 ... 15 minutes for the sensor to stabilize; use a multimeter or the transmitter display to monitor the stabilization.
6. Press buttons **Up** and **Dn** to adjust the display reading or multimeter reading to correspond the reference value (when using a multimeter calculate the current value corresponding to the reference humidity by using the equations presented in [Calculating Correspondence of Current Values and Output Quantities on page 64](#)). Press button **E** to conclude the low end adjustment.
7. If the low end adjustment is sufficient, press button **E** again to conclude the calibration and restore the DIP switch settings; set the calibration DIP switch to position disabled (down). To continue with the high end adjustment follow the instructions in next section.

High End Adjustment (Two-Point Adjustment)

1. After having made the low end adjustment, insert the probe into a measurement hole of the NaCl (75 %RH) salt chamber in the humidity calibrator. Please, note that the difference between the two humidity references must be at least 30 %RH.

NOTE

If you use serial commands, please refer to section [Adjustment Commands on page 53](#).

2. The readings measured by the transmitter appear on the display, as well as the text "Set Hi" on the lower left hand corner. If the transmitter has no display, the LED indicator lights up.
3. Wait at least 10 ... 15 minutes for the sensor to stabilize; use a multimeter or the transmitter display to monitor the stabilization.
4. Press buttons **Up** and **Dn** to adjust the display or multimeter reading (when using a multimeter calculate the current value corresponding to the reference humidity by using the equations presented in [Calculating Correspondence of Current Values and Output Quantities on page 64](#)) and conclude the adjustment with button **E**.
5. Restore the DIP switch settings. Set the calibration DIP switch to position disabled (down).

One-Point Temperature Adjustment

NOTE

Always use a high quality standard for adjusting the temperature.

NOTE

If you use serial commands, please refer to section [Adjustment Commands on page 53](#).

1. Set the internal DIP switch **Calibration Enabled/Disabled** to position **ON** and select T calibration by using switches 3 and 4 (see section [DIP Switch Functions on page 45](#)).
2. The temperature value measured by the transmitter appears on the display as well as the text "Set Lo" on the lower left corner. If the transmitter has no display, the LED indicator starts to blink.

3. Let the sensor stabilize; use a multimeter or the transmitter display to monitor the stabilization.
4. Press buttons **Up** and **Dn** to adjust the display or multimeter reading to correspond to the reference value (when using a multimeter calculate the current value corresponding to the reference humidity by using the equations presented in [Calculating Correspondence of Current Values and Output Quantities on page 64](#)). Conclude the one-point adjustment by pressing button **E** twice.

ACAL Analog Output Calibration

Syntax: **ACAL**<cr>

Connect HMT360 to a multimeter. Issue the **ACAL** command:

1. Disconnect the serial cable from the transmitter while reading the multimeter value for the Ch 1 (I1).
2. Reconnect the serial cable. Type the multimeter reading and press Enter.
3. Type the higher current multimeter reading and press Enter.

Example:

```
>acal<cr>
Ch1 I1 ( mA ) ? 4.846<cr>
Ch1 I2 ( mA ) ? 19.987<cr>
>
```

CHAPTER 7

MAINTENANCE

This chapter provides information that is needed in basic maintenance of the product.

Periodical Checking and Cleaning

Transmitter Housing and Probe

WARNING	Avoid static discharge. Always use a wet cloth for wiping the display.
----------------	--

The electronics unit of the transmitter, as well as the probe, can be removed and replaced in the field. See section [Removing the Electronics Unit on page 62](#) for detailed information.

All other maintenance must be performed by qualified Vaisala personnel. If a transmitter is damaged, contact your nearest Vaisala Service Center (see contact information [Vaisala Service Centers on page 75](#)).

CHAPTER 8

TROUBLESHOOTING

This chapter describes common problems, their probable causes and remedies, and contact information.

Diagnostics

Operation Errors

The following symptoms indicate an operation error of the HMT360:

- The analog output(s) current drops below 4 mA.
- Display shows the word "ERROR".
- The LED on the cover is lit and no calibration is going on (transmitters without display).

In the case of error:

- Check that the sensor is connected properly.
- Check if there is condensed water in the probe. If yes, let the probe dry.

In case of constant error, contact your nearest Vaisala Service Center. See section [Vaisala Service Centers on page 75](#) for contact information.

Analog Output Test

Analog outputs can be tested with dip switch 1, see [DIP Switch Functions on page 45](#) for details.

Technical Support

For technical questions, contact the Vaisala technical support:

E-mail helpdesk@vaisala.com

Fax +358 9 8949 2790

Return Instructions

If the product needs repair, please follow the instructions below to speed up the process and to avoid extra costs to you.

1. Read the section [Warranty on page 14](#).
2. Contact a Vaisala Service Center or a local Vaisala representative. The latest contact information and instructions are available from www.vaisala.com. Addresses of the Service Centers are provided in section [Vaisala Service Centers on page 75](#).

Please have the following information on hand:

- serial number of the unit
 - date and place of purchase or last calibration
 - description of the fault
 - circumstances in which the fault occurs/occurred
 - name and contact information of a technically competent person who can provide further information on the problem
3. Pack the faulty product in a strong box of adequate size, with proper cushioning material to avoid damage.
 4. Include the information specified in step 2 in the box with the faulty product. Also include a detailed return address.
 5. Ship the box to the address specified by your Vaisala contact.

Vaisala Service Centers

Vaisala Service Centers perform calibrations and adjustments as well as repair and spare part services. See contact information below.

Vaisala Service Centers also offer accredited calibrations, maintenance contracts, and a calibration reminder program. Do not hesitate to contact them to get further information.

NORTH AMERICAN SERVICE CENTER

Vaisala Inc., 10-D Gill Street, Woburn, MA 01801-1068, USA.

Phone: +1 781 933 4500, Fax: +1 781 933 8029

E-mail: us-customersupport@vaisala.com

EUROPEAN SERVICE CENTER

Vaisala Instruments Service, Vanha Nurmijärventie 21 FIN-01670 Vantaa, FINLAND.

Phone: +358 9 8949 2658, Fax: +358 9 8949 2295

E-mail: instruments.service@vaisala.com

TOKYO SERVICE CENTER

Vaisala KK, 42 Kagurazaka 6-Chome, Shinjuku-Ku, Tokyo 162-0825, JAPAN.

Phone: +81 3 3266 9617, Fax: +81 3 3266 9655

E-mail: aftersales.asia@vaisala.com

BEIJING SERVICE CENTER

Vaisala China Ltd., Floor 2 EAS Building, No. 21 Xiao Yun Road, Dongsanhuan Beilu, Chaoyang District, Beijing, P.R. CHINA 100027.

Phone: +86 10 8526 1199, Fax: +86 10 8526 1155

E-mail: china.service@vaisala.com

www.vaisala.com

CHAPTER 9

TECHNICAL DATA

This chapter provides technical data of the product.

Performance

Relative Humidity

Table 7 Relative Humidity Specifications

Property	Description / Value
Measurement range	0 ... 100 %RH
Accuracy (including non-linearity, hysteresis and repeatability)	
with HUMICAP [®] 180 and HUMICAP [®] 180R at +15 ... 25 °C at -20 ... +40 °C at -40 ... +180 °C	for typical applications for typical applications ± 1 %RH (0 ... 90 %RH) ± 1.7 %RH (90 ... 100 %RH) ±(1.0 + 0.008 × reading) %RH ±(1.5 + 0.015 × reading) %RH
with HUMICAP [®] 180L2 at -10 ... +40 °C at -40 ... +180 °C	for applications with demanding chemical environment ±(1.0 + 0.01 × reading) %RH ±(1.5 + 0.02 × reading) %RH
Factory calibration uncertainty (+20 °C)	± 0.6 %RH (0 ... 40 %RH) ± 1.0 %RH (40 ... 97 %RH) (Defined as ±2 standard deviation limits. Small variations possible, see also calibration certificate.)

Table 7 Relative Humidity Specifications

Property	Description / Value
Response time (90 %) for HUMICAP® 180 and HUMICAP® 180L2 at +20 °C in still air	8 seconds with grid filter 20 seconds with grid + steel netting 40 seconds with sintered filter
Response time (90 %) for HUMICAP® 180R at +20 °C in 0.1 m/s air flow	17 seconds with grid filter 50 seconds with grid + steel netting 60 seconds with sintered filter

Temperature (+ Operating Pressure Ranges)

Table 8 Temperature Specifications

Property	Description / Value
HMP361	-40 ... +60 °C
HMP363 80 °C	-40 ... +80 °C
HMP363 120 °C	-40 ... +120 °C
HMP364	-70 ... +180 °C, 0 ... 10 MPa (0 ... 100 bar)
HMP365	-70 ... +180 °C
HMP367	-70 ... +180 °C
HMP368	-70 ... +180 °C, 0 ... 4 MPa (0 ... 40 bar)
Accuracy at +20 °C	± 0.2 °C
Accuracy over temperature range	See graph below
Sensor	Pt 1000 RTD 1/3 Class B IEC 751

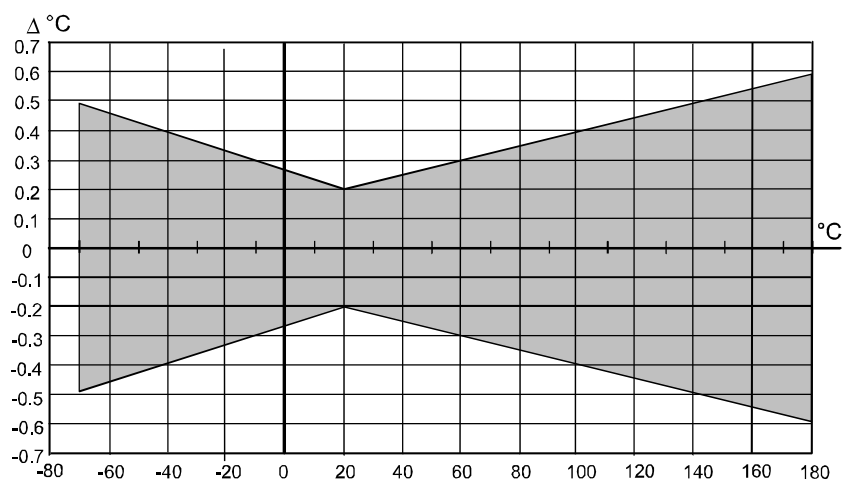

Figure 27 Accuracy over Temperature Range

Water Activity in Jet Fuel Applications

Table 9 Water Activity in Jet Fuel Applications Specifications

Property	Description / Value
Measurement range	0 ... 1 a_w at -40 ... +180 °C (-40 ... +356 °F)
Accuracy when calibrated against high quality, certified humidity standards	± 0.01 (0 ... 0.9) ± 0.02 (0.9 ... 1.0)
salt solutions (ASTM E104-85)	± 0.02 (0 ... 0.9) ± 0.03 (0.9 ... 1.0)
Response time (90 %) at +20 °C in still oil (stainless steel filter)	10 min
Humidity sensor	Vaisala HUMICAP®
Calculated variables available	mass concentration of water relative humidity of saturation saturation temperature
Accuracy of the water content	better than ± 15 % of the reading

Calculated Variables (Typical Ranges)

With HMP361 Probe

Table 10 HMP361 Calculated Variables Specifications

Property	Description / Value
Dewpoint temperature	-40 ... +60 °C
Mixing ratio	0 ... 160 g/kg d.a.
Absolute humidity	0 ... 160 g/m ³
Wet bulb temperature	0 ... +60 °C

With HMP363, HMP364, HMP365, HMP367 and HMP368 Probes

Table 11 HMP363, HMP364, HMP365, HMP367 & HMP368 Probes Calculated Variables Specifications

Property	Description / Value
Dewpoint temperature	-40 ... +100 °C
Mixing ratio	0 ... 500 g/kg d.a.
Absolute humidity	0 ... 600 g/m ³
Wet bulb temperature	0 ... +100 °C

Outputs

Table 12 Output Specifications

Property	Description / Value
Two analog outputs (one standard, one optional)	two wire 4 ... 20 mA
Typical accuracy of analog outputs at +20 °C	± 0.05 %/°C full scale
Typical temperature dependence of analog outputs	± 0.005 %/°C full scale
RS232C serial output for service use only in safe area	connector type RJ45

WARNING

Output connections are made via safety barriers.

Classification with Current Outputs

EU (94/9/EC, ATEX100a)	II 1 G EEx ia IIC T4 PTB 00 ATEX 2112 X
Safety factors:	$U_i = 28 \text{ V}$, $I_i = 100 \text{ mA}$, $P_i = 0.7 \text{ W}$ $C_i = 1 \text{ nF}$, $L_i = 0 \text{ H}$
Environmental specifications:	$T_{\text{amb}} = -20 \dots +60 \text{ }^\circ\text{C}$ $P_{\text{amb}} = 0.8 \dots 1.1 \text{ bar}$
Dust classification (with protection cover 214101):	II 1 D (IP65 $T = 70 \text{ }^\circ\text{C}$) VTT 04 ATEX 023X
U.S.A. (FM)	Classes I, II, III Division 1: Groups A - G Division 2: Groups A - D, F and G FM Project ID: 3010615
Safety factors:	$V_{\text{max}} = 28 \text{ VDC}$, $I_{\text{max}} = 100 \text{ mA}$ $C_i = 1 \text{ nF}$, $L_i = 0$, $P_i = 0.7 \text{ W}$ $T_{\text{amb}} = 60 \text{ }^\circ\text{C}$, T5
Canada (CSA)	Class 1, Divisions 1 and 2, Groups A, B, C, D Class II, Divisions 1 and 2, Groups G and Coal Dust Class III CSA File No: 213862 0 000; CSA report 1300863 $T_{\text{amb}} = 60 \text{ }^\circ\text{C}$, T4
Japan (TIIS)	Ex ia IIC T4 Code number: TC17897
Safety factors:	$U_i = 28 \text{ VDC}$, $I_i = 100 \text{ mA}$, $C_i = 1 \text{ nF}$ $L_i = 0$, $P_i = 0.7 \text{ W}$, $T_{\text{amb}} = 60 \text{ }^\circ\text{C}$
China (PCEC)	Ex ia II CT5 Certificate No. CE04052 Standard GB3686.1-2000 and GB3836.4-2000
Russia (STV)	Ex ia IIC T4 Certificate No. ROSS FI.GB04.V00634
Safety factors:	$U_i = 28 \text{ V}$, $I_i = 100 \text{ mA}$, $P_i = 700 \text{ mW}$ $C_i = 1 \text{ nF}$, $L_i = 0 \text{ H}$, $T_{\text{amb}} = -20 \text{ }^\circ\text{C} \dots +60 \text{ }^\circ\text{C}$

General

Table 13 General Specifications

Property	Description / Value
Operating voltage with serial port (service mode)	12 ... 28 V 15 ... 28 V
Connections	screw terminals, 0.33 ... 2.0 mm ² wires (AWG 14-22)
Cable bushings	M20×1.5 (7.5 ... 12 mm) M20×1.5 (10.5 ... 15 mm)
Conduit fitting	M20×1.5 / NPT 1/2"
Operating temperature range for electronics with display	-40 ... +60 °C -20 ... +60 °C
Storage temperature range	-40 ... +70 °C
Housing material	G-AISi 10 Mg (DIN 1725)
Housing classification	IP 66 (NEMA 4X)
Housing dimensions	164 × 115 × 62 mm
Housing weight	950 g
Fully electromagnetically compatible according to standards	EN 61326-1: Electrical equipment for measurement, control and laboratory use - EMC requirements; Industrial environment

NOTE

IEC 1000-4-5 complies only when using external EXi approved surge arrester on safe area.

Options and Accessories

Table 14 Options and Accessories

Item	Description / Order Code
MODULES	
Analog Output Module	HM360AOUTSP
SENSORS	
HUMICAP®180	HUMICAP180
HUMICAP®180R	HUMICAP180R
HUMICAP®180L2	HUMICAP180L2
FILTERS	
Sintered Stainless Steel Filter	HM47280SP
Stainless Steel Filter	HM47453SP
Stainless Steel Filter with Membrane	214848SP
PPS Plastic Grid with Stainless Steel Netting	DRW010281SP
PPS Plastic Grid Filter	DRW010276SP
TRANSMITTER MOUNTING ACCESSORIES	
Wall Mounting Kit	HM37108SP
Rain shield	215109
Protection cover (for use in the presence of combustible dust, ATEX)	214101
PROBE MOUNTING ACCESSORIES	
HMT363/HMP363	
Duct Installation Kit	210697
Cable Gland M20×1.5 with Split Seal	HMP247CG
Swagelok for 12mm Probe 3/8" ISO Thread	SWG12ISO38
Swagelok for 12mm Probe 1/2" NPT Thread	SWG12NPT12
HMT364/HMP364	
Fitting Body M22×1.5	17223SP
Fitting Body NPT1/2	17225SP
HMT365/HMP365	
Mounting Flange	210696
Cable Gland M20×1.5 with Split Seal	HMP247CG
HMT367/HMP367	
Duct Installation Kit	210697

Table 14 Options and Accessories

Item	Description / Order Code
Cable Gland M20x1.5 with Split Seal	HMP247CG
Swagelok for 12mm Probe 3/8" ISO Thread	SWG12ISO38
Swagelok for 12mm Probe 1/2" NPT Thread	SWG12NPT12
HMT368/HMP368	
Fitting Body ISO1/2 Solid Structure	DRW212076SP
Fitting Body NPT1/2 Solid Structure	NPTFITBODASP
Fitting Body Set ISO 1/2	ISOFITBODASP
Fitting Body Set (ISO 1/2 + NPT 1/2)	THREADSETASP
Leaking Screw with Allen Key	216027
Thread Adapter ISO1/2 to NPT1/2	210662SP
Sampling Cell with Female Connectors	DMT242SC
Sampling Cell with Swagelok Connectors	DMT242SC2
Ball Valve ISO1/2 with Welding Joint	BALLVALVE-1
Installation Flange ISO1/2	DM240FA
Manual Press	HM36854SP
CONNECTION CABLES	
Serial Interface Cable	25905ZZ
CABLE BUSHINGS	
Cable Gland M20x1.5 for 7.5...12mm Cable	216587SP
Cable Gland M20x1.5 for 10...15mm Cable	216588SP
Conduit Fitting M20x1.5 for NPT1/2 Conduit	214780SP
Dummy Plug M20x1.5 for transmitter body	214672SP
OTHER	
Calibration Adapter for HMK15	211302SP
Galvanic isolator	212483
Barrier	210664

Accuracy of Calculated Variables

Accuracy of the calculated variables depend on the calibration accuracy of the humidity and temperature sensors; here the accuracy are given for ± 2 %RH and ± 0.2 °C.

Accuracy of Dewpoint Temperature °C

Temp.	Relative humidity									
	10	20	30	40	50	60	70	80	90	100
-40	1.86	1.03	0.76	0.63	0.55	0.5	0.46	0.43	—	—
-20	2.18	1.19	0.88	0.72	0.62	0.56	0.51	0.48	—	—
0	2.51	1.37	1	0.81	0.7	0.63	0.57	0.53	0.5	0.48
20	2.87	1.56	1.13	0.92	0.79	0.7	0.64	0.59	0.55	0.53
40	3.24	1.76	1.27	1.03	0.88	0.78	0.71	0.65	0.61	0.58
60	3.6	1.96	1.42	1.14	0.97	0.86	0.78	0.72	0.67	0.64
80	4.01	2.18	1.58	1.27	1.08	0.95	0.86	0.79	0.74	0.7
100	4.42	2.41	1.74	1.4	1.19	1.05	0.95	0.87	0.81	0.76
120	4.86	2.66	1.92	1.54	1.31	1.16	1.04	0.96	0.89	0.84
140	5.31	2.91	2.1	1.69	1.44	1.26	1.14	1.05	0.97	0.91
160	5.8	3.18	2.3	1.85	1.57	1.38	1.24	1.14	1.06	0.99

Accuracy of Mixing Ratio g/kg

(Ambient pressure 1013 mbar)

Temp.	Relative humidity									
	10	20	30	40	50	60	70	80	90	100
-40	0.003	0.003	0.003	0.003	0.003	0.004	0.004	0.004	—	—
-20	0.017	0.018	0.019	0.021	0.022	0.023	0.025	0.026	—	—
0	0.08	0.09	0.09	0.1	0.1	0.11	0.11	0.12	0.13	0.13
20	0.31	0.33	0.35	0.37	0.39	0.41	0.43	0.45	0.47	0.49
40	0.97	1.03	1.1	1.17	1.24	1.31	1.38	1.46	1.54	1.62
60	2.68	2.91	3.16	3.43	3.72	4.04	4.38	4.75	5.15	5.58
80	6.73	7.73	8.92	10.34	12.05	14.14	16.71	19.92	24.01	29.29
100	16.26	21.34	28.89	40.75	60.86	98.85	183.66	438.56	—	—
120	40.83	74.66	172.36	—	—	—	—	—	—	—

Accuracy of Wet Bulb Temperature °C

Temp.	Relative humidity									
	10	20	30	40	50	60	70	80	90	100
-40	0.2	0.2	0.2	0.2	0.2	0.2	0.2	0.2	—	—
-20	0.21	0.21	0.22	0.22	0.22	0.22	0.23	0.23	—	—
0	0.27	0.28	0.28	0.29	0.29	0.29	0.3	0.3	0.31	0.31
20	0.45	0.45	0.45	0.44	0.44	0.44	0.43	0.43	0.42	0.42
40	0.84	0.77	0.72	0.67	0.64	0.61	0.58	0.56	0.54	0.52
60	1.45	1.2	1.03	0.91	0.83	0.76	0.71	0.67	0.63	0.6
80	2.23	1.64	1.32	1.13	0.99	0.89	0.82	0.76	0.72	0.68
100	3.06	2.04	1.58	1.31	1.14	1.01	0.92	0.85	0.8	0.75
120	3.85	2.4	1.81	1.48	1.28	1.13	1.03	0.95	0.88	0.83
140	4.57	2.73	2.03	1.65	1.41	1.25	1.13	1.04	0.97	0.91
160	5.25	3.06	2.25	1.82	1.55	1.37	1.24	1.13	1.05	0.99

Accuracy of Absolute Humidity g/m³

Temp.	Relative humidity									
	10	20	30	40	50	60	70	80	90	100
-40	0.004	0.004	0.005	0.005	0.005	0.006	0.006	0.006	—	—
-20	0.023	0.025	0.027	0.029	0.031	0.032	0.034	0.036	—	—
0	0.1	0.11	0.12	0.13	0.13	0.14	0.15	0.15	0.16	0.17
20	0.37	0.39	0.41	0.43	0.45	0.47	0.49	0.51	0.53	0.55
40	1.08	1.13	1.18	1.24	1.29	1.34	1.39	1.44	1.49	1.54
60	2.73	2.84	2.95	3.07	3.18	3.29	3.4	3.52	3.63	3.74
80	6.08	6.3	6.51	6.73	6.95	7.17	7.39	7.61	7.83	8.05
100	12.2	12.6	13	13.4	13.8	14.2	14.6	15	15.3	15.7
120	22.6	23.3	23.9	24.6	25.2	25.8	26.5	27.1	27.8	28.4
140	39.1	40	41	42	43	44	45	45.9	46.9	47.9
160	63.5	64.9	66.4	67.8	69.2	70.7	72.1	73.5	74.9	76.4

APPENDIX A

DIMENSIONS

This Appendix contains parts drawings of the transmitter housing, probes and some transmitter mounting accessories with metric and nonmetric dimensions specified.

HMP361

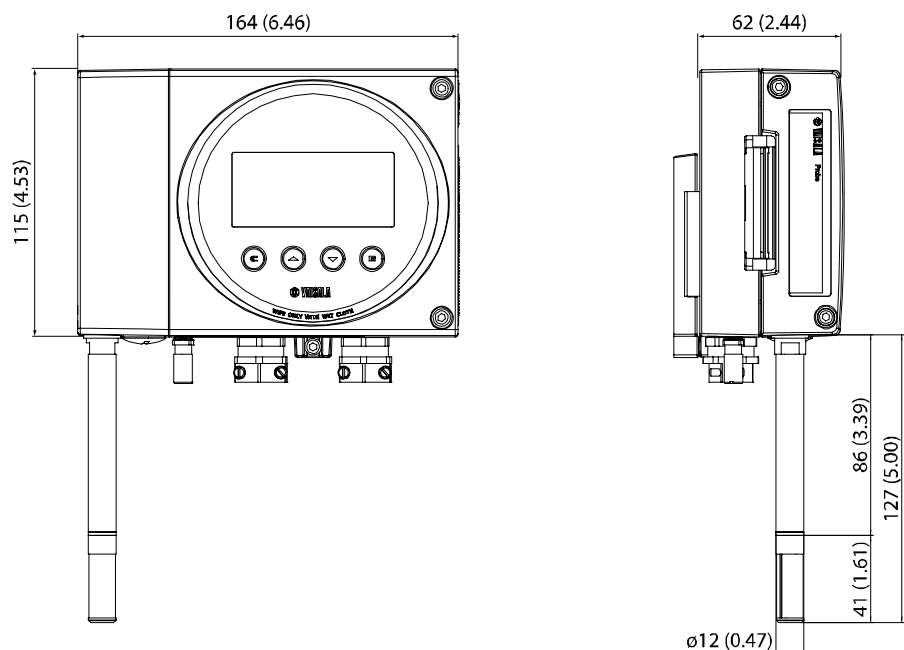

HMP363

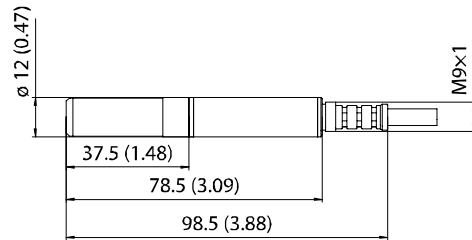

HMP364

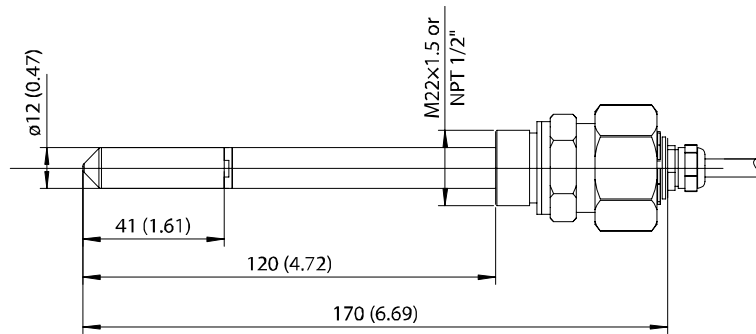

HMP365

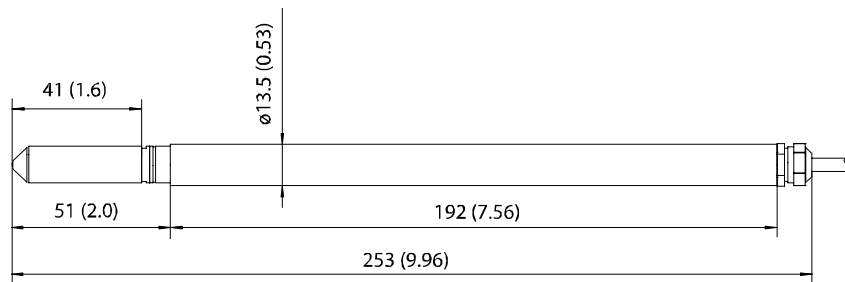

HMP367

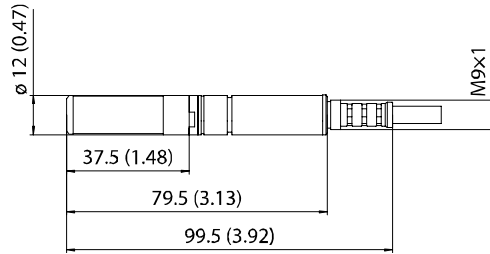

HMP368

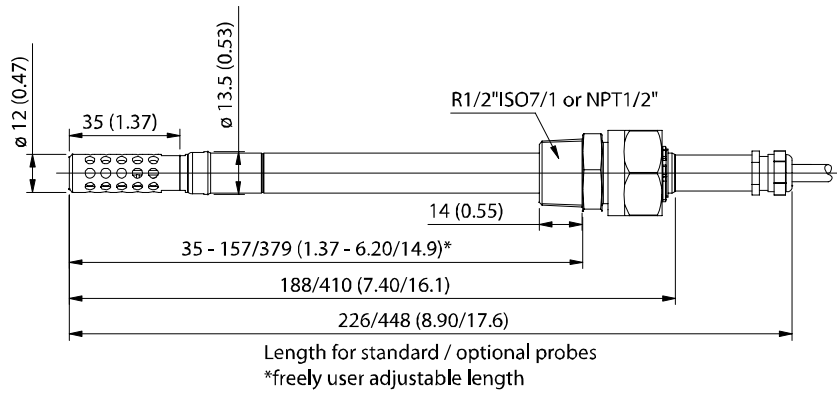

Mounting Plate

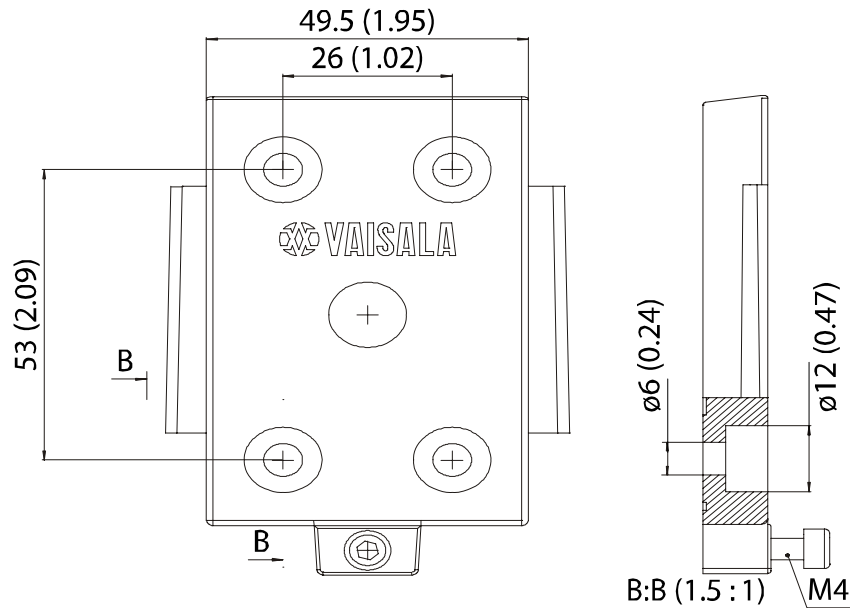

Rain Shield

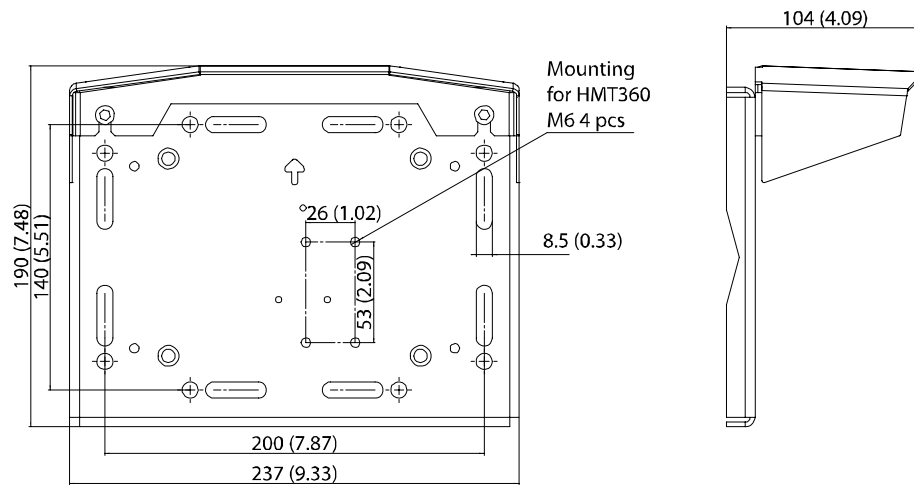

Protection Cover

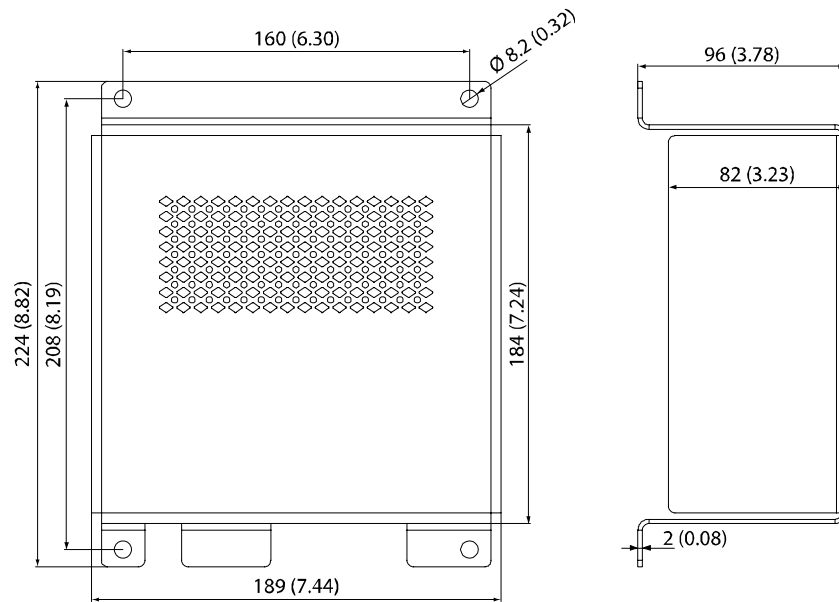

APPENDIX B
**WIRING FOR INTRINSICALLY SAFE
OPERATION, FM**

This appendix contains the wiring diagram for intrinsically safe operation approved by Factory Mutual (FM).

REV	QTY	DESCRIPTION / INFO / ECO No.	DESIGN	CHECKED / Reviewed	ACCEPTED / Approved
B		List of approved probe types added	ECO212870	RHA	RHA 06-04-24 HJJ 06-05-04

Wiring diagram for intrinsically safe operation of the HMT360-series humidity and temperature transmitter.

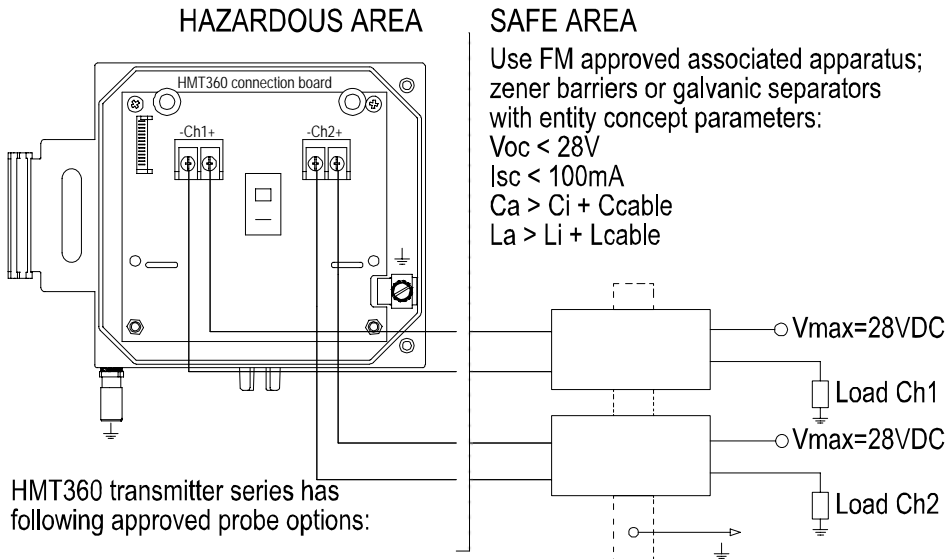

HMT360 transmitter series has following approved probe options:

HMP361, HMP362, HMP363, HMP364, HMP365, HMP367 & HMP368

HMT360-series transmitters are approved for use in Classes I, II and III, Division 1, Groups A - G and Division 2, Groups A - D, F and G.

Safety factors for HMT360-series transmitters are: $V_{max}=28V$, $I_{max}=100mA$, $C_i=1nF$, $L_i=0$, $P_i=0.7W$

NOTE:

- Barrier installation must be completed in accordance with ANSI/ISA RP 12.6 and the National Electrical Code.
- Intrinsically safe barrier ground must be less than 1 ohm.
- Maximum safe area voltage is 250V.

General tolerance	ISO 2768-m	Design				
Material	Weight	Supplier code				
Finish		DOCUMENT CREATION DATA		Title	Assembly Instruction	
		Creator	01-07-18 ARH			YYY-MM-DD
		Review	01-11-19 ARH	Size	Code	
FIRST ANGLE PROJECTION	DIMENSIONS ARE IN MILLIMETERS, UNLESS OTHERWISE SPECIFIED	Approved	05-04-11 RHA	DRW211603		Rev
		Archive ID	ACAD	Scale		B
			Sheet	of		

APPENDIX C

WIRING FOR INTRINSICALLY SAFE OPERATION, CSA

This appendix contains the wiring diagram for intrinsically safe operation approved by the Canadian Standards Association (CSA).

Rev	Qty	Change	Revision	ECO no	Design	Date/Revise	Date App
C		Probe types and barrier/isolator info updated	ECO212844		KKe	2006-06-20 RHA	2006-06-20 HJJ

Wiring diagram for intrinsically safe operation of the HMT360-series humidity and temperature transmitter.

HAZARDOUS AREA

Max cable length 2000ft (600m)

Vaisala offers following barrier and galvanic isolator types:

Manufacturer:	Type:	Vaisala code:
Barrier: R. Stahl	9001/51-280-091-141	210664
Isolator: R. Stahl	9160/13-11-11	212483

If other barrier or galvanic isolator types are used, Vaisala or CSA do not take responsibility for the selected barrier's or galvanic isolator's suitability!

Cable parameters shall be less than 60pF/ft (197pF/m) and 0.2µH/ft (0.67µH/m). The maximum cable length is 2000ft (600m).

SAFE AREA

HMT360-series transmitters are approved for use in Division 1 and 2, Class I, Groups A, B, C, and D. Division 1, and 2, Class II, Group G and coal dust. Division 1, and 2, Class III.

NOTE:

1. Each channel must be supplied through separate shielded cables.
2. When using galvanic separators CH1- and CH2- must be short circuited with an external wire.
3. When using transmitter in Class I, Division 2 the main switch shall not be operated or the unit shall not be disconnected unless power has been switched off, or area is known to be non hazardous.
4. Use only conduit connection in Division 2.
5. Substitution on components may impair intrinsic safety or suitability for Division 2.
6. Only intrinsically safe installation is allowed in Class II and Class III environments.
7. Intrinsically safe barrier ground must be less than 1 ohm.
8. Maximum safe area voltage is 250V.

HMT360-series transmitters shall be used with following probes:

- Probe HMP361 with 127mm long pipe.
- Probe HMP362 with 2, 5 or 10 m length cable
- Probe HMP363 with 2, 5 or 10 m length cable
- Probe HMP364 with 2, 5 or 10 m length cable
- Probe HMP365 with 2, 5 or 10 m length cable
- Probe HMP367 with 2, 5 or 10 m length cable
- Probe HMP368 with 2, 5 or 10 m length cable

The material for associated cable is FEP (Tetrafluoropropylene) or for HMP363 also PUR (Polyurethane) available.

To avoid static discharge shall the cable cover with conductive material.

Drawn	KKe 2002-08-21	Arch	No	Sertif	No	Check	Cooperator's	Doc no
Revised	IML 2002-10-06	Installation Drawing		Vaisala Oyj Vanhanurmijärventie 21 Vantaa Finland				
Appr	KKe 2002-10-06					Dwg no	Rev	
Design	DRW213478B					DRW213478	C	

APPENDIX D **CERTIFICATES**

This Appendix contains copies of the EXi intrinsically safe certificates issued for the HMT360 series.

Physikalisch-Technische Bundesanstalt
Braunschweig und Berlin



(1) **EC-TYPE-EXAMINATION CERTIFICATE**
(Translation)

(2) Equipment and Protective Systems Intended for Use in Potentially Explosive Atmospheres - **Directive 94/9/EC**



(3) EC-type-examination Certificate Number:
PTB 00 ATEX 2112 X

(4) Equipment: Humidity and temperature transmitter type HMT 360

(5) Manufacturer: Vaisala Oyj

(6) Address: Vanha Nurmijärventie 21, FIN-01670 Vantaa

(7) This equipment and any acceptable variation thereto are specified in the schedule to this certificate and the documents therein referred to.

(8) The Physikalisch-Technische Bundesanstalt, notified body No. 0102 in accordance with Article 9 of the Council Directive 94/9/EC of 23 March 1994, certifies that this equipment has been found to comply with the Essential Health and Safety Requirements relating to the design and construction of equipment and protective systems intended for use in potentially explosive atmospheres, given in Annex II to the Directive.

The examination and test results are recorded in the confidential report PTB Ex 00-29165.

(9) Compliance with the Essential Health and Safety Requirements has been assured by compliance with:
EN 50014:1997 EN 50020:1994 EN 50284:1999

(10) If the sign "X" is placed after the certificate number, it indicates that the equipment is subject to special conditions for safe use specified in the schedule to this certificate.

(11) This EC-type-examination Certificate relates only to the design and construction of the specified equipment in accordance with Directive 94/9/EC. Further requirements of this Directive apply to the manufacture and supply of this equipment.

(12) The marking of the equipment shall include the following:

II 1 G EEx ia IIC T4

Zertifizierungsstelle Explosionsschutz
By order:

Braunschweig, November 28, 2000

Dr.-Ing. U. Johannsmeyer
Regierungsdirektor



sheet 1/3

EC-type-examination Certificates without signature and official stamp shall not be valid. The certificates may be circulated only without alteration. Extracts or alterations are subject to approval by the Physikalisch-Technische Bundesanstalt. In case of dispute, the German text shall prevail.

Physikalisch-Technische Bundesanstalt • Bundesallee 100 • D-38116 Braunschweig

Physikalisch-Technische Bundesanstalt
Braunschweig und Berlin



SCHEDULE

(13)

(14) **EC-TYPE-EXAMINATION CERTIFICATE PTB 00 ATEX 2112 X**

(15) Description of equipment

The humidity and temperature transmitter type HMT 360 Exi is used for the measurement of temperature and humidity in the explosion hazardous area.

The humidity and temperature transmitter type HMT 360 Exi is intended for operation with the following associated sensor heads:

HMP 361	probe for wall-mounting
HMP 363	application for confined space
HMP 364	application for over pressure
HMP 365	application for high temperatures
HMP 368	application for pressure pipes or in liquids

The maximum permissible ambient temperature is +60 °C.

Electrical Data

Supply circuits type of protection Intrinsic Safety EEx ia IIC resp. EEx ia IIB;
(terminals CH1 +, CH1 - only for connection to certified intrinsically safe circuits with
resp. CH2 +, CH2 -) linear output characteristic and an internal resistance of
 $R_i \geq 300 \Omega$

Maximum values per channel:

$U_i = 28 \text{ V}$
 $I_i = 100 \text{ mA}$
 $P_i = 700 \text{ mW}$
 $C_i = 1 \text{ nF}$
 L_i negligibly low

(16) Test report PTB Ex 00-29165

sheet 2/3

EC-type-examination Certificates without signature and official stamp shall not be valid. The certificates may be circulated only without alteration. Extracts or alterations are subject to approval by the Physikalisch-Technische Bundesanstalt. In case of dispute, the German text shall prevail.

Physikalisch-Technische Bundesanstalt • Bundesallee 100 • D-38116 Braunschweig

Physikalisch-Technische Bundesanstalt



Braunschweig und Berlin

SCHEDULE TO EC-TYPE-EXAMINATION CERTIFICATE PTB 00 ATEX 2112 X

(17) Special conditions for safe use

1. The sensor heads (also the separately mounted versions with a connecting cable of max. 10 m) as well as the transmitter type HMT 360 may be used in areas which require apparatus of category 1 for equipment group II. The ambient conditions have to comply with the atmospheric conditions according to EN 50284 (temperature range -20 °C up to +60 °C, absolute pressure range 0.8 bar up to 1.1 bar).
2. The humidity and temperature transmitter type HMT 360 Exi may be used in areas which require apparatus of category 1 for equipment group IIC if the danger of an ignition due to electrostatic charge, e.g. if non-conductive media flow along the transmitter's window, is impossible.
With the application of variants of the humidity and temperature transmitter type HMT 360 Exi without display in areas, which require category-1-apparatus for equipment group IIC, there is no ignition danger due to a possible electrostatic charge.
3. With the installation of the sensor heads in an area which requires category-1-apparatus for equipment group II it has to be ensured that sparks due to impact or friction do not occur, not even in rare cases of fault.
4. In the area which requires the application of category-1-apparatus for equipment group IIC the associated cable of the sensor heads has to be installed as such that it is protected against electrostatic charge. In the area which requires the application of category-1-apparatus there is no danger of ignition due to a possible electrostatic charge for explosion group IIB.
5. With the operation of the humidity and temperature transmitter type HMT 360 Exi in areas which require category-1-apparatus for equipment group II the supply circuits have to be connected to intrinsically safe supply units with safe electrical isolation of these circuits from all other circuits.
6. The serial interface must only be used outside the explosion hazardous area for the purpose of calibration or test. The associated serial interface cable 25905ZZ is to be used.

(18) Essential health and safety requirements

met by standards

Zertifizierungsstelle Explosionsschutz
By order:

Braunschweig, November 28, 2000

Dr.-Ing. U. Johannsmeyer
Regierungsdirektor



sheet 3/3

EC-type-examination Certificates without signature and official stamp shall not be valid. The certificates may be circulated only without alteration. Extracts or alterations are subject to approval by the Physikalisch-Technische Bundesanstalt. In case of dispute, the German text shall prevail.

Physikalisch-Technische Bundesanstalt • Bundesallee 100 • D-38116 Braunschweig



EC-TYPE EXAMINATION
CERTIFICATE
VTT 04 ATEX 023X

1 (2)



1. **EC-TYPE EXAMINATION CERTIFICATE**

2 **Equipment or Protective Systems Intended for use in
Potentially explosive atmospheres
Directive 94/9/EC**

3. Reference: **VTT 04 ATEX 023X**

4. Equipment: **Humidity and temperature transmitter assembly**
Certified types: **HMT360**

5. Manufactured by: **Vaisala Oyj**

6. Address: **Vanha Nurmijärventie 21
FIN-01670 Vantaa
Finland**

7. This equipment and any acceptable variations thereto is specified in the schedule and possible supplement(s) to this certificate and the documents therein referred to.

8. VTT Industrial Systems, notified body number 0537, in accordance with Article 9 of the Council Directive 94/9/EC of March 1994, certifies that the assembly has been found to comply with the Essential Health and Safety Requirements relating to the design and construction of equipment and protective systems intended for use in potentially explosive atmospheres given in Annex II to the Directive.

9. The examination and test results are recorded in confidential Report no TUO26-044075.

10. Compliance with the Essential Health and Safety Requirements has been assured by compliance with:

EN 50281-1-1 (1998)

VTT INDUSTRIAL SYSTEMS
Electrical Ex-apparatus
Otakaari 7B, Espoo
P.O.Box 13071, FIN-02044 VTT, Finland

Tel + 358 9 4561
Fax + 358 9 456 7042





EC-TYPE EXAMINATION
CERTIFICATE
VTT 04 ATEX 023X

2 (2)

11. If the sign "X" is placed after the certificate number, it indicates that these equipment is subject to special conditions for safe use specified in the schedule to this Certificate
12. This EC-Type examination certificate relates only to the design, examination and tests of the specified equipment in accordance to the directive 94/9/EC.

Further requirements of the Directive may apply to the manufacturing process and supply of these equipment. These are not covered by this certificate.
13. The marking of the equipment shall include the following:



II 1 D IP 65 T = 70 °C

Espoo, 7.4.2004

VTT INDUSTRIAL SYSTEMS
Electrical Ex-apparatus



I018
(EN45004, liite A)

Martti Siirola
Research scientist

Risto Sulonen
Senior research scientist

Certificate without signatures shall not be valid.
This certificate, including the schedule, may only be reproduced in its entirety and without any change.



Member of the FM Global Group

FM Approvals
1151 Boston-Providence Turnpike
P.O. Box 9102 Norwood, MA 02062 USA
T: 781 762 4300 F: 781 762 9375 www.fmapprovals.com

CERTIFICATE OF COMPLIANCE

HAZARDOUS (CLASSIFIED) LOCATION ELECTRICAL EQUIPMENT

This certificate is issued for the following equipment:

HMT36abcdehijklm. Transmitter and Probe or Transmitter only

IS / I, II, III / I / ABCDEFG / T5 Ta = 60°C — DRW211603, Entity;

NI / I, / 2 / ABCD / T5 Ta = 60°C; S / II, / 2 / FG / III / T5 Ta = 60°C

Entity Parameters:

Terminals	Vmax	I _{max}	P _{max}	Ci	Li
Ch 1: + and -	28V	100mA	0.7W	1nF	0μH
Ch 2: + and -	28V	100mA	0.7W	1nF	0μH

a = Probe type: 0, 1, 2, 3, 4, 5, 7, or 8.

b = Transmitter type: (any single letter) A - Z.

c = Display: 1 or 2.

d = Output channels: 1 or 2.

e = Analog output signal (Ch1): (any single letter) A - Z.

f = Analog output signal (Ch 2): (any single letter) A - Z.

g = Output range: (any single letter) A - Z.

h = Units: 1 or 2.

i = Cable bushings: A, B, or C.

j = Manual: Any single letter A-Z

k = Cable length: (any single letter) A - Z or 0, 1, 2, or 3

l = Humidity sensor: 1, 2, 3, 4, 5, 6, 7, or 8

m = Sensor protection: 0, 1, 2, 3, 4, 5, 6, or 7

n = Installation kit: A-Z or 0.

Equipment Ratings:

Intrinsically Safe Class I, II, III, Division 1, Groups A, B, C, D, E, F, & G; also as Class I, Zone 0, AEx ia IIC; in accordance with Entity requirements when installed per installation drawing DRW211603; and Nonincendive Class I, Division 2, Groups A, B, C, & D; Class II, Division 2, Groups F & G, Class III for use in indoor hazardous (classified) locations with a temperature rating of T5, Ta = 60°C.



Approved for:

Vaisala Oyj
P.O. Box 26
FIN-00421 Helsinki FINLAND



This certifies that the equipment described has been found to comply with the following FM Approval Standards and other documents:

Class 3600	1998
Class 3610	1999
Class 3611	1999
Class 3810	1989
Including supplement #1	1995

Original Project ID: 3010615

Approval Granted: January 9, 2002

Subsequent Revision Reports / Date Approval Amended

Report Number	Date	Report Number	Date
3016167	March 14, 2003	3017701	August 7, 2003
3010615	November 3, 2003		
051221	5/24/06		

FM Approvals LLC

 David W. Styracula
 Technical Team Manager

5/24/06
 Date



Certificate of Compliance

Certificate: 1300863

Master Contract: 213862

Project: 1300863

Date Issued: August 30, 2002

Issued to: Vaisala Oyj
P.O. Box 26
Helsinki, FIN-00421
FINLAND

Attention: Mr. Kari Kettu

The products listed below are eligible to bear the CSA Mark shown



Issued by: 
Dorin Stochitoiu

Authorized by: 
Nick Alfano
Operations Manager

PRODUCTS

CLASS 2258 03 - PROCESS CONTROL EQUIPMENT - Intrinsically Safe - For Hazardous Locations

Class I, Div.1 and Div.2, Groups A, B, C and D; Class II, Div.1 and Div.2, Groups G and Coal Dust; Class III

HMT 360 series, humidity and temperature transmitters, rated 28V, 4-20 mA, and provides intrinsically safe outputs to HMP36* series probe when connected as per installation drawing DRW213478, Maximum ambient temperature 60°C, Temperature Code T4.

APPLICABLE REQUIREMENTS

- | | | |
|-------------------|-----------|--|
| CSA Std C22.2 No. | 142-M1987 | -Process Control Equipment |
| CSA Std C22.2 No. | 213-M1987 | -Non-Incendive Electrical Equipment for Use in Class I, Division 2 Hazardous Locations |
| CSA Std C22.2 No. | 157-1992 | -Intrinsically Safe and Non-Incendive Equipment for Use in Hazardous Locations |



防爆構造電気機械器具型式検定合格証

申請者	東京都新宿区神楽坂六丁目42番地 ヴァイサラ株式会社		
製造者	Vanha Nurmiarventie 21, FIN-01670 Vantaa, FINLAND Vaisala Oyj		
品名	湿・温度変換器		
型式の名称	HMT360 7D22HKD2B7BX1A1A (同一型式は別表のとおり)		
防爆構造の種類	本質安全防爆構造 (ia)		
対象ガス又は蒸気の 爆発等級及び発火度	IICT4		
定格	チャンネル1回路 許容電圧 28V 許容電流 100mA 許容電力 700mW 内部インダクタンス 無視できる値 内部キャパシタンス 1nF チャンネル2回路 許容電圧 28V 許容電流 100mA 許容電力 700mW 内部インダクタンス 無視できる値 内部キャパシタンス 1nF 周囲温度 60℃		
使用条件			
型式検定合格番号	第 TC17897 号		
有効期間	平成19年 4月 4日 から 平成22年 4月 3日まで		
	平成 年 月 日 から 平成 年 月 日まで		
	平成 年 月 日 から 平成 年 月 日まで		
	平成 年 月 日 から 平成 年 月 日まで		

機械等検定規則による型式検定に合格したことを証明する。

平成19年 4月 4日

型式検定実施者 社団法人 産業安全技術協会長

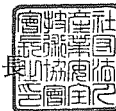



No. L0381
中国国家认证认可监督管理委员会
China State Accreditation Administration

防爆合格证

CONFORMITY CERTIFICATE OF EXPLOSION-PROOF

证 号
Certificate No. CE042052

产品名称 Name of Product	温湿度变送器
型号及规格 Type of Product	HMT360 系列
防爆标志 Marking	Exia II CT5
技术文件 Technical Documents	U336EN-1.1
图 号 Drawing No.	/
备 注 Note (s)	HMT360 系列产品包含以下型号: HMT361/363/364/365/368。

经对上述产品图样及技术文件的审查和样品的检验,其符合以下中国现行标准:
By verifying the drawings and technical documents and checking samples, the product comply with the following standards that is currently valid in PRC:

GB3836.1-2000 GB3836.4-2000

发 给: 维萨拉公司
Issued to: Vaisala Company

本证失效日期: 2009-05-28
Date of Expire: 2009-05-28

发证日期: 2004-05-28
Date of Issue: 2004-05-28

中心印章
Center seal



中心主任
Director



石油和化学工业电气产品防爆质量监督检验中心

Supervision and Test Center of Explosion-proof Quality for Petroleum and Chemical Industry Electric Products

注:本证仅对与送检样品一致的产品有效。
Note: This certificate is only valid for the products that are in accord with sample(s) tested and verified.
中心地址:中国天津市丁字沽三号路 83 号 邮政编码:300131 电话/传真:022-26541594
Center Add: No.83 No.3 Road DingZiGu Tianjin China Post code: 300131 Tel/ Fax: 022-26541594
E-mail:cec@pceec.com http://www.pceec.com



ФЕДЕРАЛЬНАЯ СЛУЖБА
ПО ЭКОЛОГИЧЕСКОМУ, ТЕХНОЛОГИЧЕСКОМУ И АТОМНОМУ НАДЗОРУ

РАЗРЕШЕНИЕ № РСР 00-22190

На применение

Оборудование (техническое устройство, материал):
Измерители влажности и температуры серии НМТ типов НМТ 361,
НМТ 362, НМТ 363, НМТ 364, НМТ 365, НМТ 368 с маркировкой
взрывозащиты 0ЕхiaПСТ4.

Код ОКП (ТН ВЭД): 42 1551 (9025 80 910 0)

Изготовитель (поставщик): Фирма "Vaisala Oyj" (Финляндия).

Основание выдачи разрешения: Сертификат соответствия ЦС "СТВ"
№ РОСС FI.ГБ04.В00634 от 15.08.2006 г.

Условия применения:

1. Применять на поднадзорных производствах и объектах в соответствии с Руководством по эксплуатации, а также требованиями главы 7.3 ПУЭ.
2. Внесение изменений в техническую документацию и конструкцию технических устройств возможно только по согласованию с аккредитованной испытательной организацией и Федеральной службой по экологическому, технологическому и атомному надзору.

Срок действия разрешения до 15.09.2009

Дата выдачи 15.09.2006

Заместитель руководителя
Н.Г. Кутьин



AA 011747